



INSTALLATION, OPERATION &
MAINTENANCE MANUAL

E8KT/E10KT/E12KT
ENERGY STORAGE SYSTEM

Copyright Statement

Please keep the manual properly and operate in strict accordance with all safety and operating instructions in this manual. Please do not operate the system before reading through the manual.

Contact the nearest hazardous waste disposal station when the products or components are discarded.

CONTENTS

01	Introduction	01
1.1	System Introduction	01
1.2	Operation Modes	03
1.3	Safety Introduction	04
1.4	Battery Safety Datasheet	06
1.5	General Precautions	07
1.6	Parts List	08
1.7	System Appearance	14
1.8	Liability Limitation	17
02	Installation	18
2.1	Installation Site and Environment	18
2.2	Installation	20
2.3	External CT Connection	31
2.4	DRED Port Connections (optional,only for DRM function)	32
2.5	COMM Port Connections	32
2.6	METER+DRY Port Connections	33
2.7	Single Line Diagram	33
03	System Operation	35
3.1	Switch on	35
3.2	Switch off	36
3.3	Emergency Procedure	37
04	EMS Introduction and Set up	38
4.1	Function Description	38
4.2	Display and Setting	39
4.3	Configuration Menus Overview	44
05	Battery Storage And Recharging	55
5.1	Battery Storage Requirements	55
5.2	Storage Expirations	55
5.3	Inspection Before Battery Recharging	55
06	Stick Logger Quick Guide	56
6.1	Download APP	56
6.2	Stick Logger Installation	56
6.3	Logger Status	57
6.4	Abnormal State Processing	57
6.5	Usage Methods and Notices for Reset Button	59
07	SOLARMAN Smart APP	60
7.1	Registration	60
7.2	Create a Plant	60
7.3	Add a Logger	60
7.4	Network Configuration	61
08	Alarm Code and Error Code	63
8.1	Alarm Code	63
8.2	Error Code	64
09	Fault Diagnosis and Solutions	65
10	Product Specifications	68
11	Routine Maintenance	73
12	Quality Assurance	75

01 Introduction

1.1 System Introduction

E8KT/E10KT/E12KT can be applied in DC- coupled systems (mostly new installation), AC- coupled systems (mostly retrofit) and Hybrid-coupled systems (mostly retrofit, and PV capacity-increase), as the following schemes show:

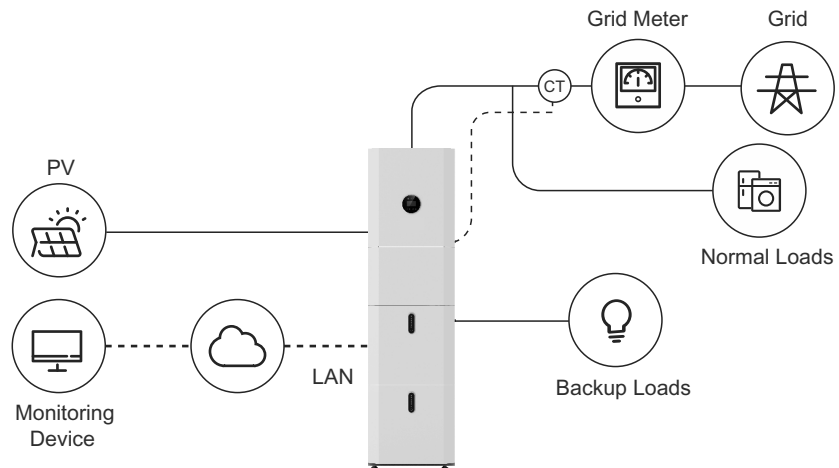

Figure1 DC-coupled Storage System – Scheme

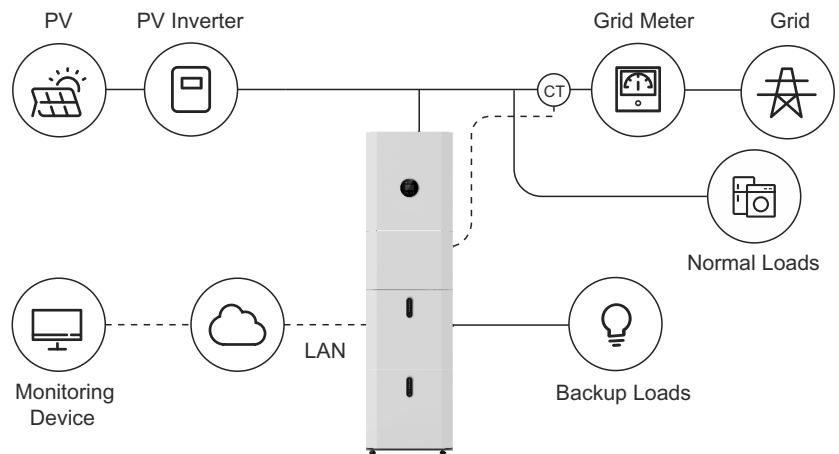

Figure 2 AC-coupled Storage System–Scheme

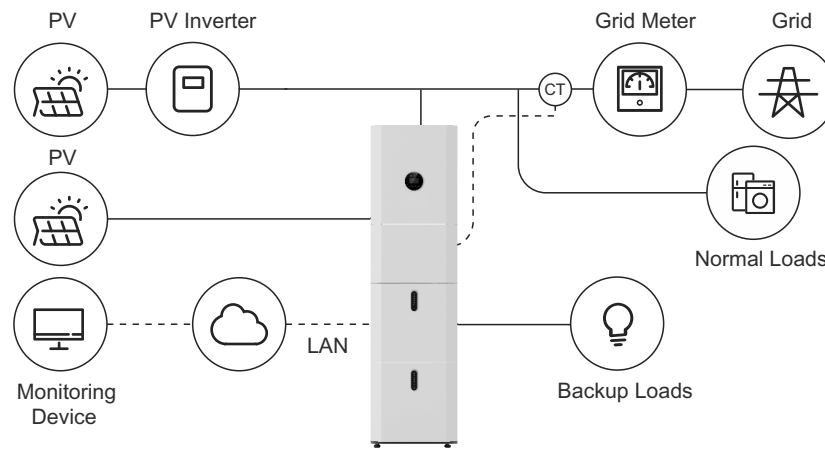
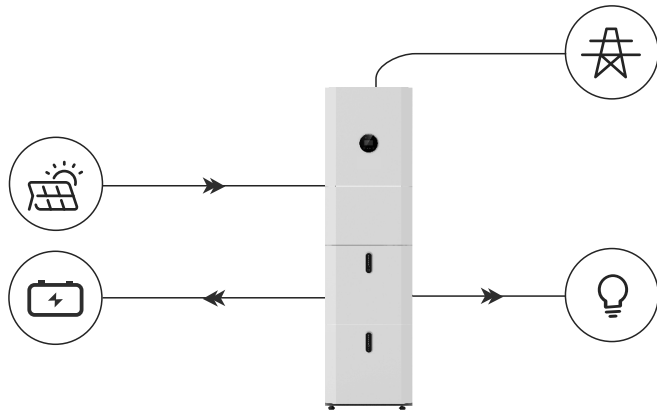

Figure 3 Hybrid-coupled Storage System–Scheme

1.2 Operation Modes:

There are three basic modes that end users can choose via inverter screen/APP.

• **SELF CONSUME:** The energy generated by the solar panels will be used in the following order: Feed the home loads; Charge the battery and then, feed into the grid. When the sun is off, the load will be supported by battery to enhance self consumption. If the power supply from the batteries is not sufficient, the grid will support the load demand.



• **BAT PRIORITY:** Under this mode, the battery is only used as a backup power supply when the grid fails and as long as the grid works, the batteries won't be used to power the loads. The battery will get charged with the power generated by the PV system or from the grid.

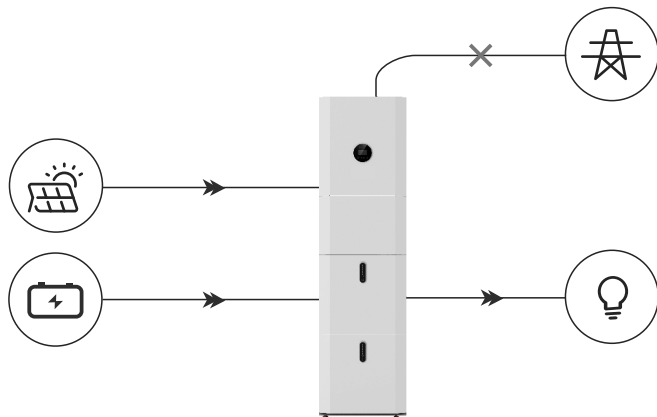

• **PEAK SHIFT:** This mode is designed for time-use mode customer. The customer is able to set up the charging/discharging time & power via inverter screen or APP.

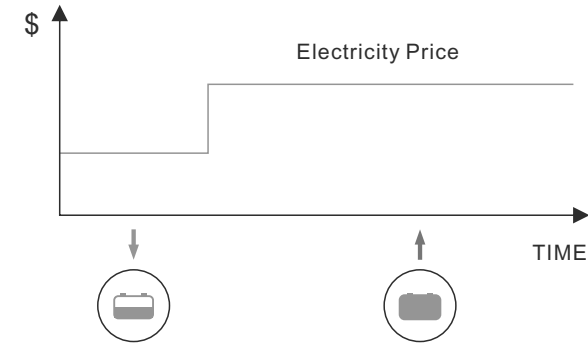

1.3 Safety Introduction

1.3.1 Manual Keeping

This manual contains important information about operating the system. Before operating, please read it very carefully. The system should be operated in strict accordance with the instructions in the manual, otherwise it can cause damages or loss to equipment, personnel and property. This manual should be kept carefully for maintenance.

1.3.2 Operator Requirements

The operators should get a professional qualification, or be trained. The operators should be familiar with the whole storage system, including compositions and working principles of the system. The operators should be familiar with the Product Instruction. While maintaining, the maintainer is not allowed to operate any equipment until all the equipment has been turned off and fully discharged.

1.3.3 Protection of Warning Sign

The warning signs contain important information for the system to operate safely, and it is strictly prohibited to tear or damage them. Ensure that the warning signs are always well-functioned and correctly placed. The signs must be replaced immediately when damaged.



This sign indicates a hazardous situation which, if not avoided, could result in death or serious injury!



The E8KT/E10KT/E12KT must not be touched or put into service until 5 minutes after it has been switched off or disconnected to prevent an electric shock or injury.



This sign shows danger of hot surface!



Refer to the operating instructions.

1.3.4. Setting of Warning Sign for Safety

During instruction, maintenance and repair, follow the instructions below to prevent non-specialist personnel from causing misuse or accident:

- Obvious signs should be placed at front switch and rear switch to prevent accidents caused by false switching.
- Warning signs should be set near operating areas.
- The system must be reinstalled after maintenance or operation.

1.3.5 Measuring Equipment

To ensure the electrical parameters to match requirements, related measuring equipment are required when the system is being connected or tested. Ensure that the connection and use matched specification to prevent electric arcs or shocks.

1.3.6 Moisture Protection

It is very likely that moisture may cause damages to the system. Repair or maintaining activities in wet weather should be avoided or limited.

1.3.7 Operation After Power Failure

The battery system is part of the energy storage system which stores life-threatening high voltage even when the DC side is switched off. Touching the battery outlets is strictly prohibited. The inverter can keep a life-threatening voltage even after disconnecting it from the DC and / or AC side. Therefore, for safety reasons, it must be tested with a properly calibrated voltage tester before an installer works on the equipment.

1.3.8. Information on environmental conservation and recycling



This Symbol indicates that the marked device must not be disposed of as normal household waste. It must be disposed of at a collection center for the recycling of electric and electronic equipment.

1.4 Battery Safety Datasheet

1.4.1 Hazard Information

Classification of the hazardous chemical

Exempt from classification according to Australian WHS regulations.

Other hazards

This product is a Lithium Iron Phosphate Battery with certified compliance under the UN Recommendations on Transport of Dangerous Goods, Manual of Tests and Criteria, Part III, subsection 38.3. For the battery cell, chemical materials are stored in a hermetically sealed metal case, designed to withstand temperatures and pressures encountered during normal use. As a result, during normal use, there is no physical danger of ignition or explosion and chemical danger of hazardous materials' leakage. However, if the product is exposed to a fire, added mechanical shocks, decomposed, added electric stress by misuse, the gas release vent will be operated. The battery cell case will be breached at the extreme. Hazardous materials may be released. Moreover, if heated strongly by the surrounding fire, acrid or harmful fume may be emitted.

1.4.2 Safety Datasheet

For detailed information please refer to the provided battery safety datasheet.

1.5 General Precautions

⚠ DANGER

Danger to life due to high voltages of the PV array, battery and electric shock. When exposed to sunlight, the PV array generates dangerous DC voltage which will be present in the DC conductors and the live components of the inverter. Touching the DC conductors or the live components can lead to lethal electric shocks. If you disconnect the DC connectors from the system under load, an electric arc may occur leading to electric shock and burns.

- ◆ Do not touch uninsulated cable ends.
- ◆ Do not touch the DC conductors.
- ◆ Do not open the inverter and battery.
- ◆ Do not wipe the system with damp cloth.
- ◆ Have the system installed and commissioned by qualified personnel with the appropriate skills only.
- ◆ Prior to performing any work on the inverter or the battery pack, disconnect the inverter from all voltage sources as described in this document.

⚠ WARNING

Risk of chemical burns from electrolyte or toxic gases. During standard operation, no electrolyte shall leak from the battery pack and no toxic gases shall form. Despite careful construction, if the Battery Pack is damaged or a fault occurs, it is possible that electrolyte may be leaked or toxic gases formed.

- ◆ Do not install the system in any environment of temperature below -25°C or over 60°C and in which humidity is over 90%.
- ◆ Do not touch the system with wet hands.
- ◆ Do not put any heavy objects on top of the system.
- ◆ Do not damage the system with sharp objects.
- ◆ Do not install or operate the system in potentially explosive atmospheres or areas of high humidity.
- ◆ Do not mount the inverter and the battery pack in areas containing highly flammable materials or gases.
- ◆ If moisture has penetrated the system (e.g. due to a damaged enclosure), do not install or operate the system.
- ◆ Do not move the system when it is already connected with battery modules. Secure the system to prevent tipping with restraining straps in your vehicle.
- ◆ The transportation of E8KT/E10KT/E12KT must be made by the manufacturer or an instructed personnel. These instructions shall be recorded and repeated.

- ◆ A certified ABC fire extinguisher with minimum capacity of 2kg must be carried along when transporting.
- ◆ It is totally prohibited to smoke in the vehicle as well as close to the vehicle when loading and unloading.
- ◆ For the exchange of a battery module, please request for new hazardous goods packaging if needed, pack it and let it be picked up by the suppliers.
- ◆ In case of contact with electrolyte, rinse the affected areas immediately with water and consult a doctor without delay.

⚠ CAUTION:









Risk of injury through lifting or dropping the system. The inverter and battery are heavy. There is risk of injury if the inverter or battery is lifted incorrectly or dropped during transport or when attaching to or removing from the wall.

- ◆ Lifting and transporting the inverter and battery must be carried out by more than 2 people.

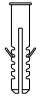

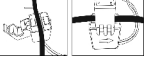

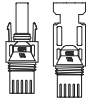
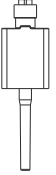
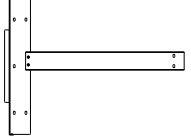
1.6 Parts List

Check the following parts list to ensure it is complete.

Delivers a total system separately on site to client, this consists of:

Inverter					
					
6×M5*12	5×ST6.3*50	5×D10*50	2×CT Connector	3×CT and com cable	2×AC Collector
					
4×MC4	1×Collector	1×Mounting Panel	1×COM Connector	1×User Manual	

PACK5.1

			
4×ST6.3*50	4×D10*50	2×M5*12	4×M6 Gasket

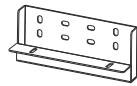

1×Mounting Panel

Accessory - Cable (PACK10.2)

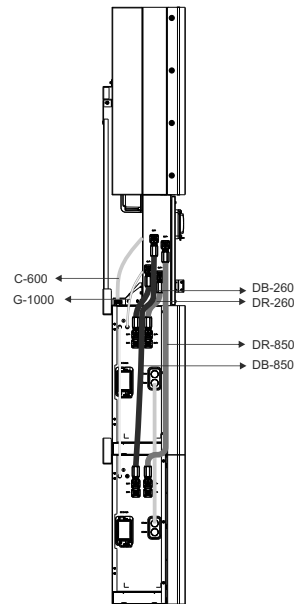
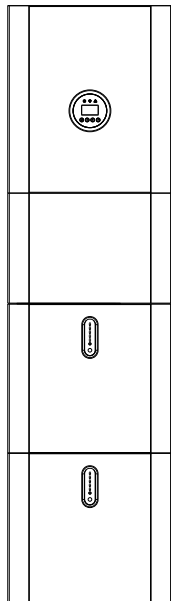

Accessory - Cable (PACK20.4)

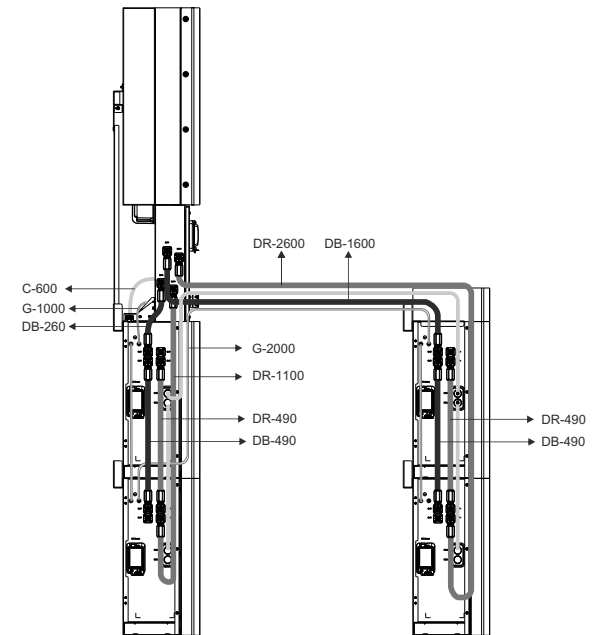
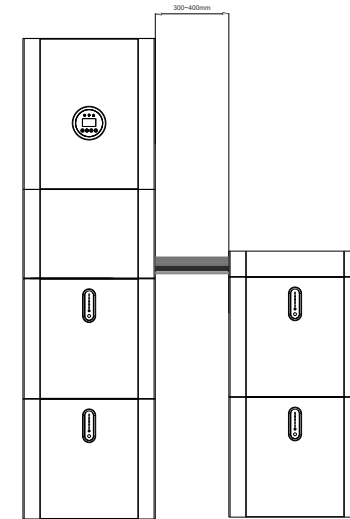

Accessory - Cable (PACK30.6)

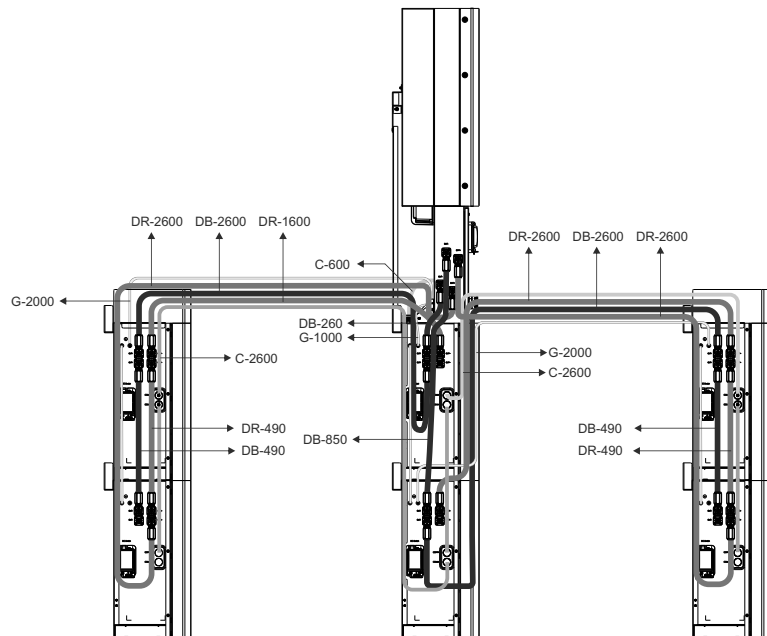
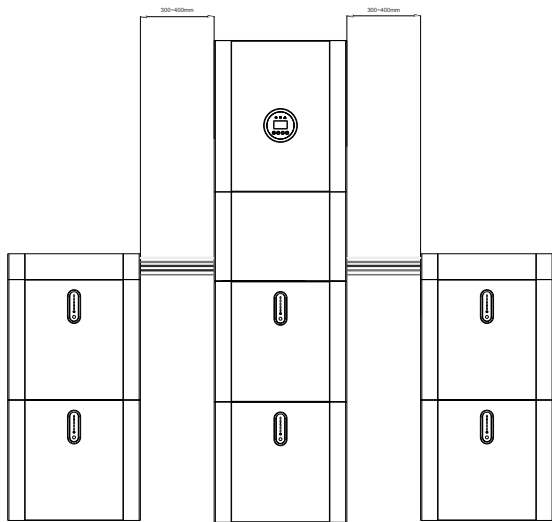

Accessory - Cable (PACK40.8)

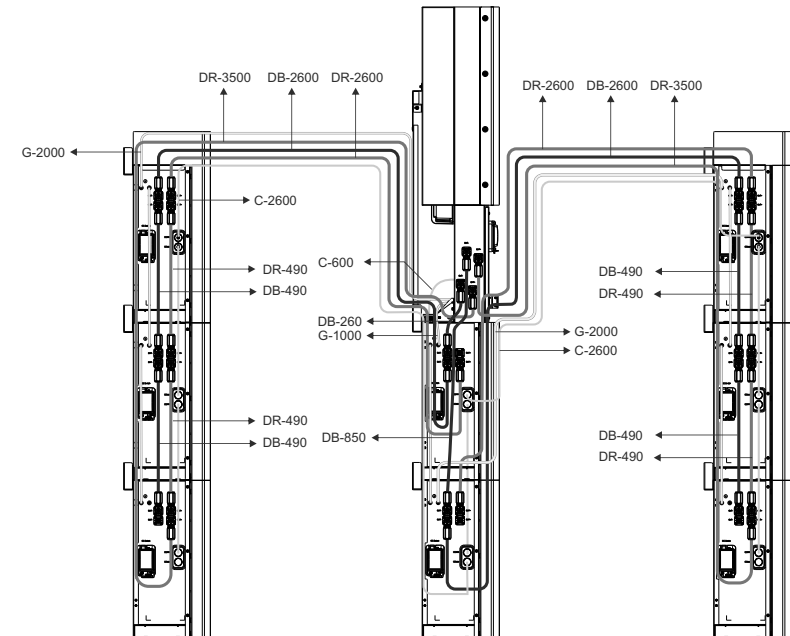
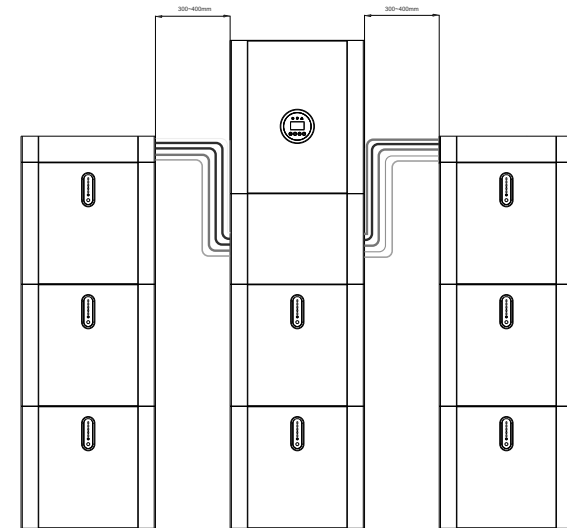

Accessory - Mechanical Top cover

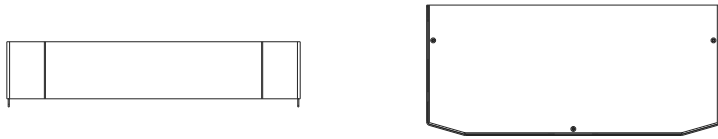

Accessory - Floor stand support

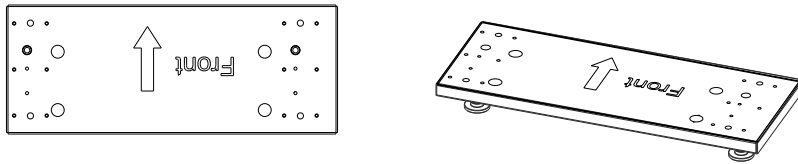

1.7 System Appearance

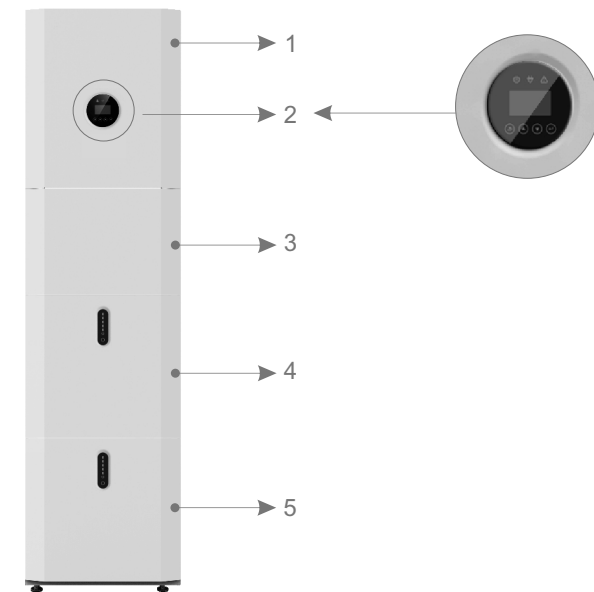

Figure 4 E8KT/E10KT/E12KT Delivery Scope

Object	Description
1	Hybrid Inverter
2	EMS Display Screen
3	Cable Box (connected to Inverter)
4	PACK5.1 (Battery 1)
5	PACK5.1 (Battery 2, if configured)

1.7.1 Cable Box Part

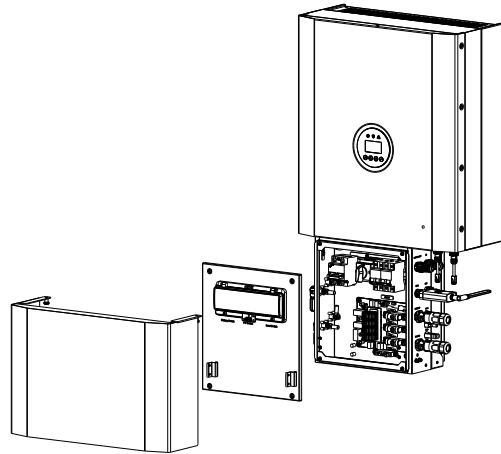

Figure 5 Inverter without Cable Box Covers– Front View

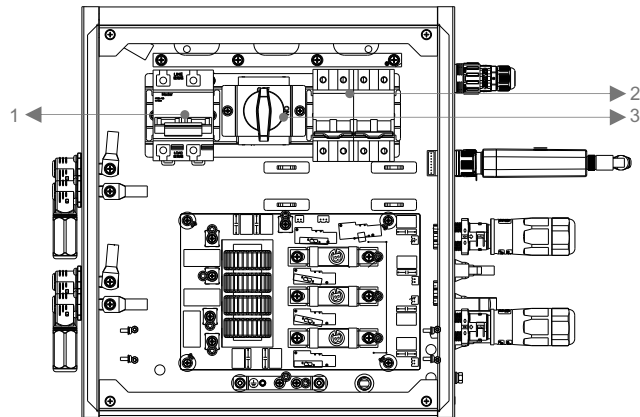

Figure 6 Cable Box Part without Covers – Front View

Object	Description
1	Battery circuit breaker
2	Output terminal block (BACK UP)
3	DC isolation switch

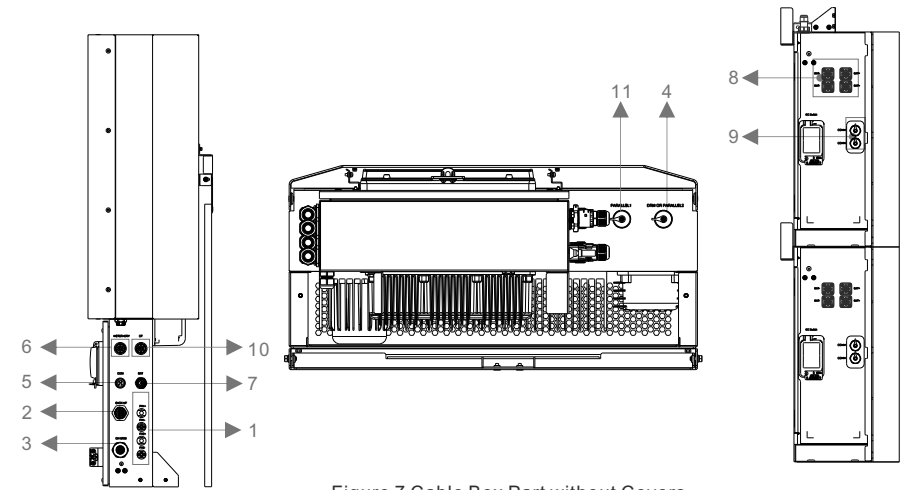

Figure 7 Cable Box Part without Covers

Object	Description	DVC class	Object	Description	DVC class
1	PV1, PV2	DVC C	2	BACKUP	DVC C
3	ON GRID	DVC C	4	DRM OR PARALLEL2	DVC A
5	COM	DVC A	6	METER+DRY	DVC A
7	BAT	DVC A	8	BAT+,BAT-	DVC A
9	COMM	DVC A	10	CT	DVC A
11	PARALLEL1	DVC A			

Note: The DVC indicates the minimum required level of protection for the circuit.

Decisive voltage Classification (DVC)	Limits of working voltage V		
	a.c. voltage r.m.s. U_{ACL}	a.c. voltage peak U_{ACPL}	d.c. voltage mean U_{DCL}
A*	≤25 (16)	≤35.4 (22.6)	≤60 (35)
B	50 (33)	71 (46.7)	120 (70)
C	> 50 (> 33)	> 71 (> 46.7)	> 120 (> 70)

The table values in parentheses are to be used for PCE or portions of PCEs rated for installation in wet locations as addressed in 6.1 for environmental categories and minimum environmental conditions.

*DVC-A circuits are allowed under fault conditions to have voltages up to the DVC-B limits, for maximum 0.2 s.

1.8 Liability Limitation

Any product damage or property loss caused by the following conditions, Company does not assume any direct or indirect liability.

- Product modified, design changed or parts replaced without Company authorization;
- Changes, repair attempts and erasing of series number or seals by Non-Company technician;
- System design and installation are not in compliance with standards and regulations;
- Fail to comply with the local safety regulations (VDE for DE, SAA for AU);
- Transport damage (including painting scratch caused by rubbing inside packaging during shipping). A claim should be made directly to shipping or insurance company in this case as soon as the container/packaging is unloaded and such damage is identified;
- Fail to follow any/all of the user manual, the installation guide and the maintenance regulations;
- Improper use or misuse of the device;
- Insufficient ventilation of the device;
- The maintenance procedures relating to the product have not been followed to an acceptable standard;
- Force majeure (violent or stormy weather, lightning, overvoltage, fire etc.);
- Damages caused by any external factors.

02 Installation

This Manual introduces the basic steps to install and set up E8KT/E10KT/E12KT.

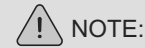

NOTE:

Please be cautious unpacking the battery, otherwise components could be damaged.

2.1 Installation Site and Environment

2.1.1 General

This E8KT/E10KT/E12KT energy storage system is outdoor version and can be installed in an outdoor location.

When E8KT/E10KT/E12KT systems are installed in a room, E8KT/E10KT/E12KT must not be hampered by the structure of the building, the furnishings and equipment of the room.

The E8KT/E10KT/E12KT is naturally ventilated. The location should therefore be clean, dry and adequately ventilated. The mounting location must allow free access to the unit for installation and maintenance purposes, and the system panels must not be blocked.

The following locations are not allowed for installation:

- Habitable rooms;
- Ceiling cavities or wall cavities;
- On roofs that are not specifically considered suitable;
- Access / exit areas or under stairs / access walkways;
- Where the freezing point can be reached, such as garages, carports or other places as well as wet rooms (environmental category 2);
- Locations with humidity and condensation over 95%;
- Places where salty and humid air can penetrate;
- Seismic areas - additional security measures are required;
- Sites with altitude over 2000m;
- Places with an explosive atmosphere;
- Locations with direct sunlight or a large change in the ambient temperature;
- Places with flammable materials or gases or an explosive atmosphere.

2.1.2 Restricted Locations

The E8KT/E10KT/E12KT shall not be installed :

1. In restricted locations as defined for panels in AS / NZS 3000;
2. Within 600mm of any heat source, such as hot water unit, gas heater, air conditioning unit or any other appliance.
3. Within 600mm of any exit;
4. Within 600mm of any window or ventilation opening;
5. Within 600mm of side of other device.

A E8KT/E10KT/E12KT installed in any corridor, hallway, lobby or the like and leading to an emergency exit shall ensure sufficient clearance for safe egress of at least 1 meter. The E8KT/E10KT/E12KT must also not be installed in potentially explosive atmospheres for gas cylinders that are heavier than air gases and have a vent clamp in accordance with AS / NZS 3000.

2.1.3 Barrier to Habitable Rooms

To protect against the spread of fire in living spaces where the E8KT/E10KT/E12KT is mounted or on surfaces of a wall or structure in living spaces with a E8KT/E10KT/E12KT on the other side, the wall or structure shall have a suitable non-combustible barrier. If the mounting surface itself is not made of a suitable non-combustible material, a non-combustible barrier can be placed between the E8KT/E10KT/E12KT and the surface of a wall or structure. If the E8KT/E10KT/E12KT is mounted at a wall or at a distance of 300mm from the wall or the structure separating it from the habitable space, the distances to other structures or objects must be increased. The following distances must remain free:

- (i) 600 mm beside the E8KT/E10KT/E12KT;
- (ii) 500 mm above the E8KT/E10KT/E12KT;
- (iii) 600 mm before the E8KT/E10KT/E12KT.

If the distance between the E8KT/E10KT/E12KT and the ceiling or any object above the system is less than 500mm, the ceiling or structural surface above the system must be made of noncombustible material within a radius of 600mm around the system.

The E8KT/E10KT/E12KT must be mounted to ensure the highest point is not more than 2.2m above the ground or the platform.

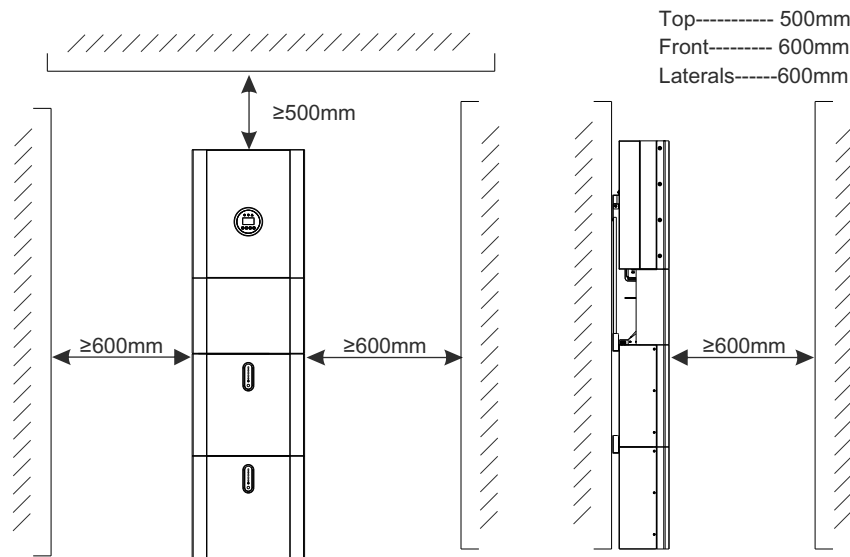

Figure 8 Limited Distance of Installation to Neighboring Objects

2.2 Installation

Step 1 Remove the battery and inverter from the packaging box.

2.2.1 Battery Installation

Step 2 Assemble the battery mounting panel on the battery.

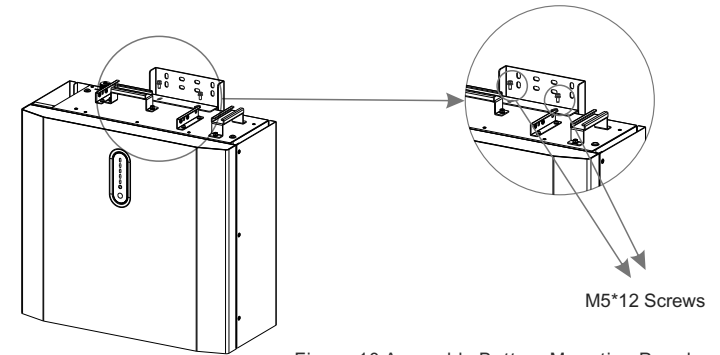

Figure 10 Assemble Battery Mounting Panel

Step 3 Position the battery parallel to the wall and use a $\Phi 8$ mm drill to drill holes at a depth of about 70mm in the wall for subsequent fixation of the mounting plates.

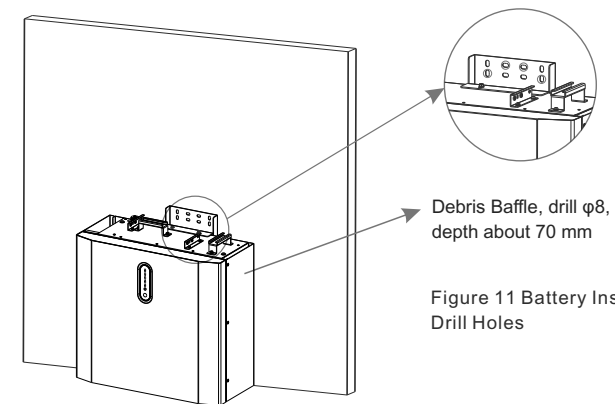

Figure 11 Battery Installation - Drill Holes

NOTE:

The type B RCD must be installed on the backup port of the system according to local regulations .

Step 4 Remove the debris baffle and secure the battery to the wall with screws and gaskets.

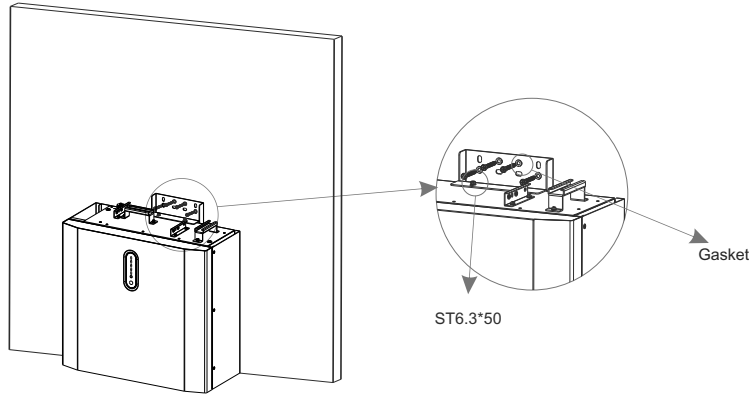

Figure 12 Battery Installation – Mounting on the Wall

Step 5 To assemble the second (and all other) battery, repeat steps 6 and 7, respectively.

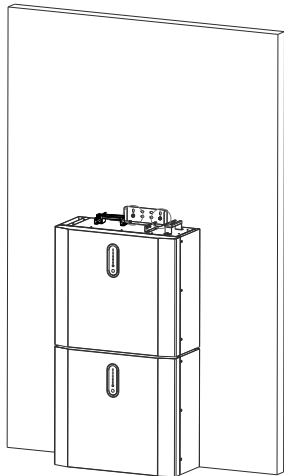

Figure 13 Battery Installation
Second Battery Installation

2.2.2 Inverter Installation

Step 6 Inverter Installation.

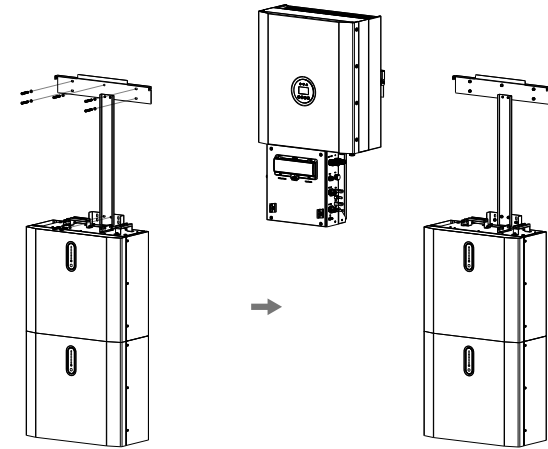

Figure 14 Inverter Installation

Step 7 Hang the inverter onto the mounting panels, adjust the entire system and ensure that the battery and the inverter have been securely hung onto the panels and brackets.

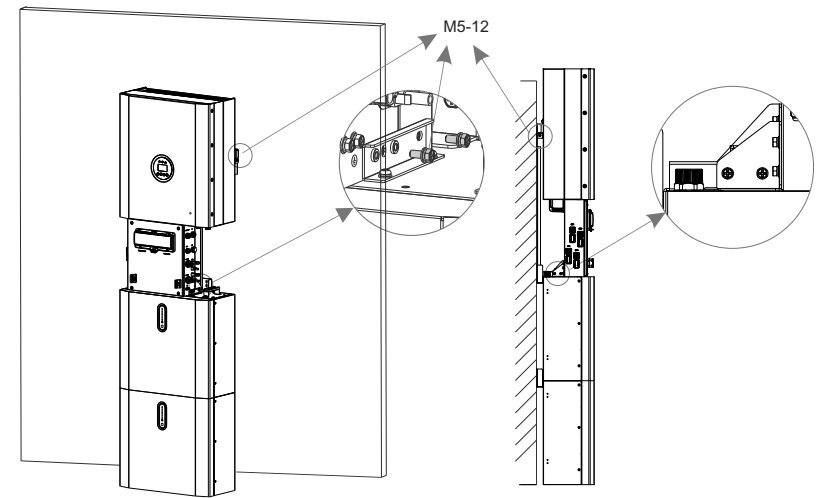



Figure 15 Inverter Installation on the Wall

Step 8 Please make AC cables on site.

Step 8-1 Please follow the AC cable requirements below.

For backup connection, 12AWG or 4mm² cable is required to be used. For grid connection, 10AWG or 6mm² cable is required to be used. Please make sure the resistance of cable is lower than 1 ohm. If the wire is longer than 20m, it's recommended to use 10AWG or 6mm² cable for backup and 8AWG or 8mm² cable for grid.

WARNING:
 There are "L1,L2,L3" "N" "PE" symbols marked inside the connector, the Line wire of grid must be connected to "L1,L2,L3" terminal; the Neutral wire of grid must be connected to "N" terminal; the Earth of grid must be connected to "PE"

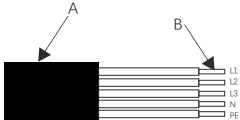

Object	Description	Value
A	External diameter	10mm
B	Copper conductor cross-section	6mm ²

b. Insert the conductor into the suitable ferrule acc. to DIN 46228-4 and crimp the contact.

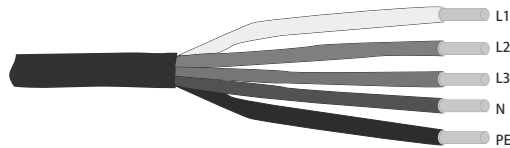

b

c. Unscrew the swivel nut from the threaded sleeve and thread the swivel nut and threaded sleeve over the AC cable.

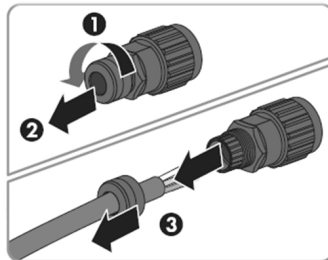

c

d. Insert the crimped conductors L, N and PE into the corresponding terminals and tighten the screw with a hex key wrench screw driver (size:2.5, 1.2~2.0 N.m). Ensure that all conductors are securely in place in the screw terminals on the bush insert.

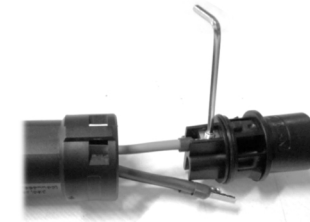

d

e. Screw the swivel nut onto the threaded sleeve. This seals the AC connector and provides strain relief for the AC cable. When doing so, hold the bush insert firmly by the locking cap. This ensures that the swivel nut can be screwed firmly onto the threaded sleeve.

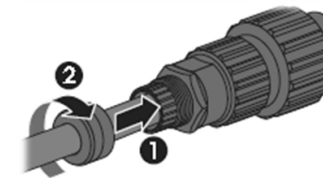

e

f. Assemble the plug shell ,adapter as below picture, Push the adapter and Shell by hand until a "Click" is heard or felt.

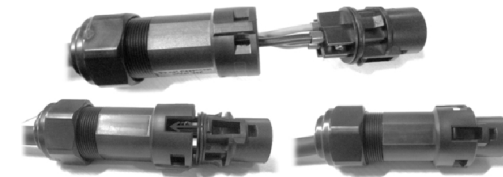

f

g. Plug the AC connector into the jack for the AC connection by hand until a "Click" is heard or felt.

(8) Use tool to clamp the AC wiring terminal and wire rod; screw the nut, but do not tighten it. Make sure that the cable is free to pass through the waterproof components. Once the terminal is connected to the right site of the inverter, tighten the nut.

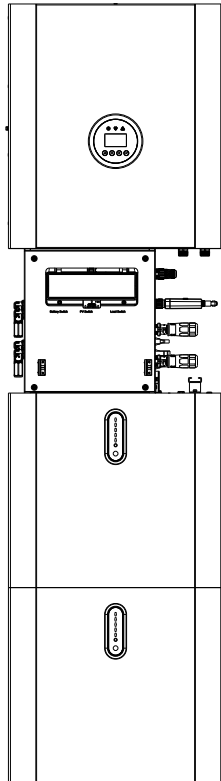

Figure 16

(9) Connect the AC wiring terminal to the corresponding hole site of the inverter and lock it with a screw driver or electric screw driver (suggestion: stem diameters and torsion of screwdriver or electric screwdriver should be 4mm and 8~12kg-f.cm respectively)

(10) Tighten the nut.

(11) Circuit breaker parameters are recommended:

Back-up 25A/400Vac 6KA
On-grid 32A/400Vac 6KA

Step 8-2 Connect the Backup and Grid cables in advance according to the connector mode, and connect them to the Backup and Grid board connectors in turn.

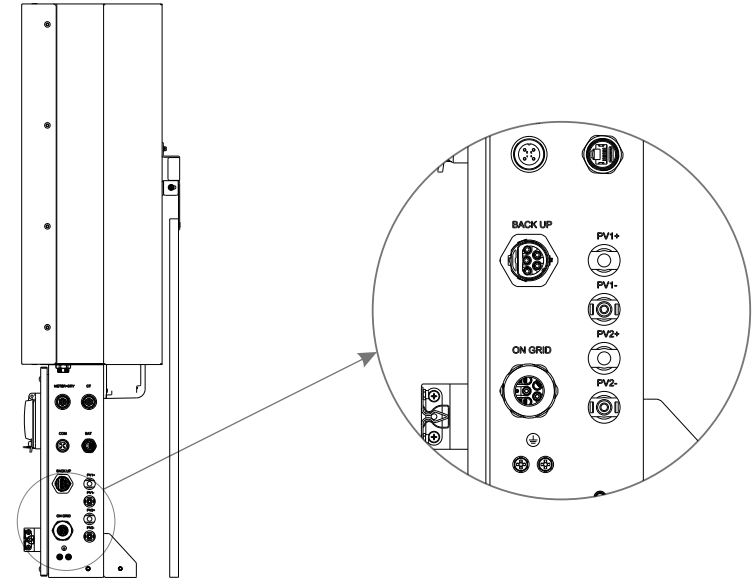

Figure 17 Cable Box Bottom View, Wiring Connectors

Step 9 Connect the BAT communication cable of the cable box from Step 13 to the topmost battery at the right side. Then use the communication cable supplied with the batteries to connect the batteries to each other via the respective connectors on the left side. After you have connected all the modules together, close all covers (if you want to connect further battery modules, you must mount them before closing).

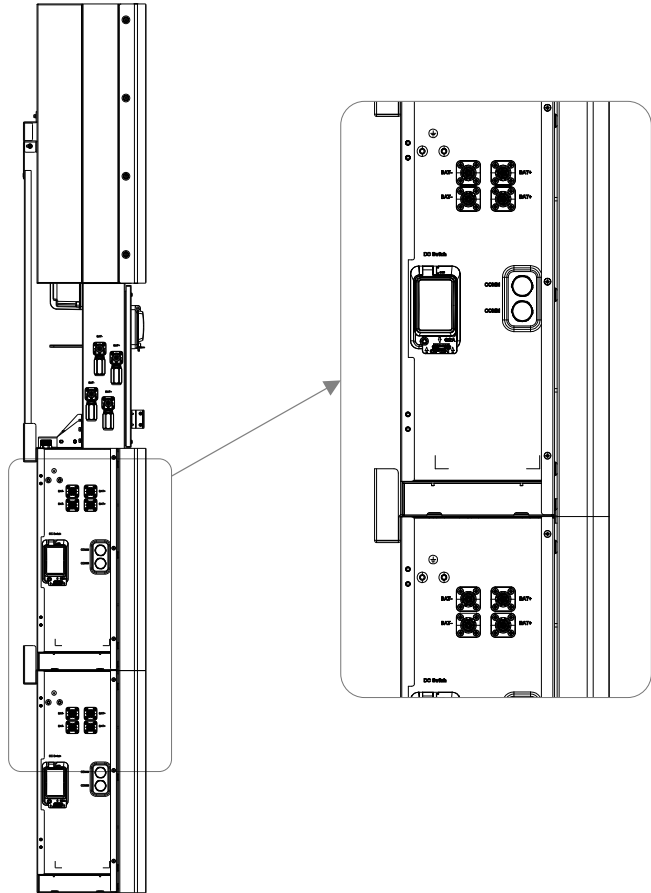

Figure 19 Wiring the Communication Cable

Step 10 Connect the power cables of the bottom battery from Step 4 to the side terminals of the top battery. Make sure that red connects to red and black connects to black.

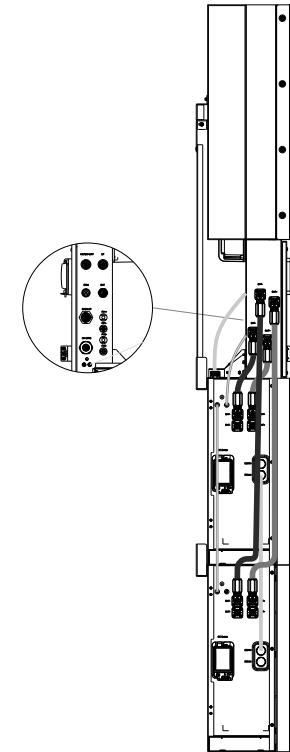

Figure 20 Wiring the Battery Power Cable

Step11 Close the battery covers and connect the PV-MC4 connectors to the system (connection on both sides). Also, connect all AC cables, the meter communications cable METER, and the Ethernet cable LAN. Then close the cable box cover. The installation is now complete.

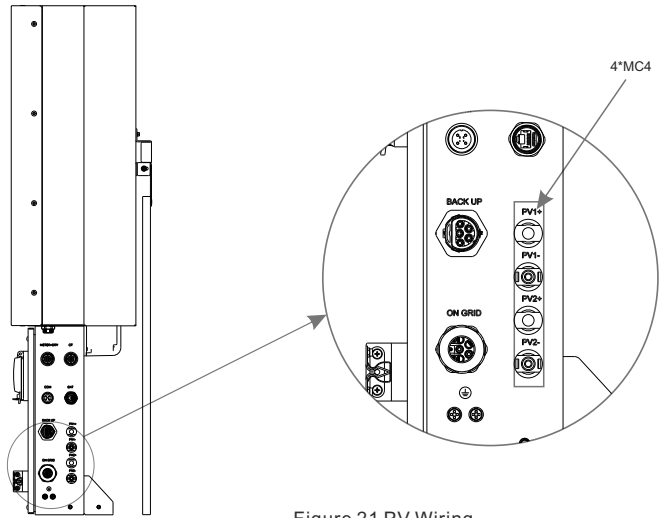

Figure 21 PV Wiring

NOTE:

Recommended AC circuit breaker rating is 32A for grid, 25A for backup.

NOTE:

It is necessary to disconnect the power line, communication line and communication line between battery pack and inverter to manually sleep all battery packs.

STATEMENT:

The method of anti-islanding protection is power variation

Step12 Close the lid and tighten the screw.

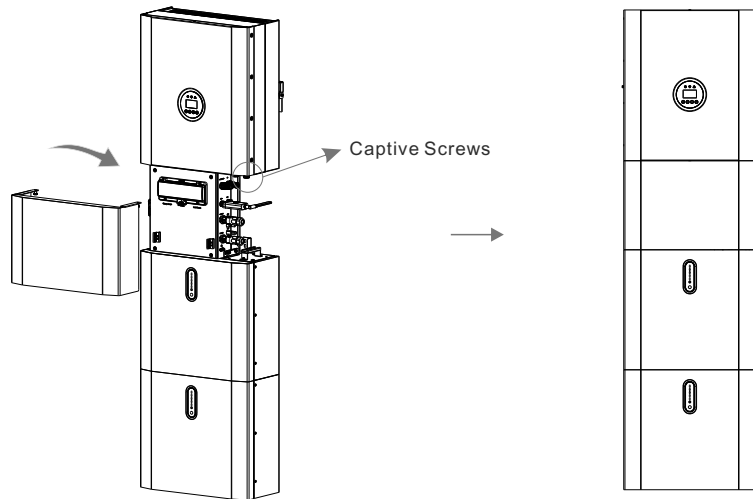

Figure 22

2.3 External CT connection

The electricity meter should be mounted and connected at the grid transition point (feed-in point) so that it can measure the grid reference and feed-in power.

1. Loosen the nut, and untangle the single-aperture sealing ring.

Pin	Description	Pin	Description
1	R phase CT positive electrode(White)	2	R phase CT negative pole(Black)
3	S phase CT positive electrode(White)	4	S phase CT negative pole(Black)
5	T phase CT positive electrode(White)	6	T phase CT negative pole(Black)

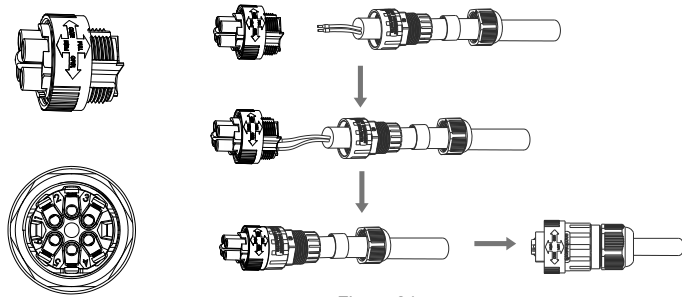
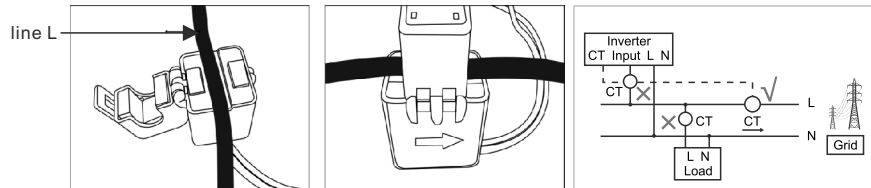

Figure 24

2. Install the waterproof component and screw on the waterproof sheath nut.
3. Open the external CT wiring port, the arrow points to the direction of the power grid, put the wire into the external CT card slot, and buckle the buckle.



NOTE:

External CT should be placed near the power grid. If CT test pass but inverter still can't achieve export power (power is not controllable or always 0 power output).Please check installation location of the CT.

2.4 DRED Port Connections (optional,only for DRM function)

DRED means demand response enable device. The AS/NZS 4777.2:2015 required inverter need to support demand response mode(DRM). This function is for inverter that comply with AS/NZS 4777.2:2015 standard. Inverter is fully comply with all DRM. A 8P terminal is used for DRM connection.

Pin	Description	Pin	Description
1	GND	5	DRM 4/8
2	+5V	6	DRM 3/7
3	Com/DRM 0	7	DRM 2/6
4	+5V	8	DRM 1/5

Please follow below figure to assemble DRM connector.

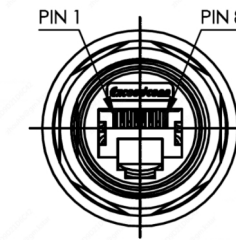
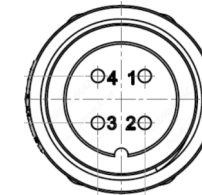

Figure 25 DRM connector

2.5 COMM Port Connections



Pin	Description	Pin	Description
1	+5V	3	RS485-B
2	GND	4	RS485-A

2.6 METER+DRY Port Connections

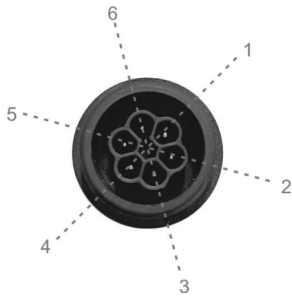

Pin	Description	Pin	Description
1	DRY conctact	4	I/O
2	DRY conctact	5	RS485-B
3	GND	6	RS485-A

2.7 Single Line Diagram

The single line diagrams of DC-, AC- and Hybrid-coupled system are as below:

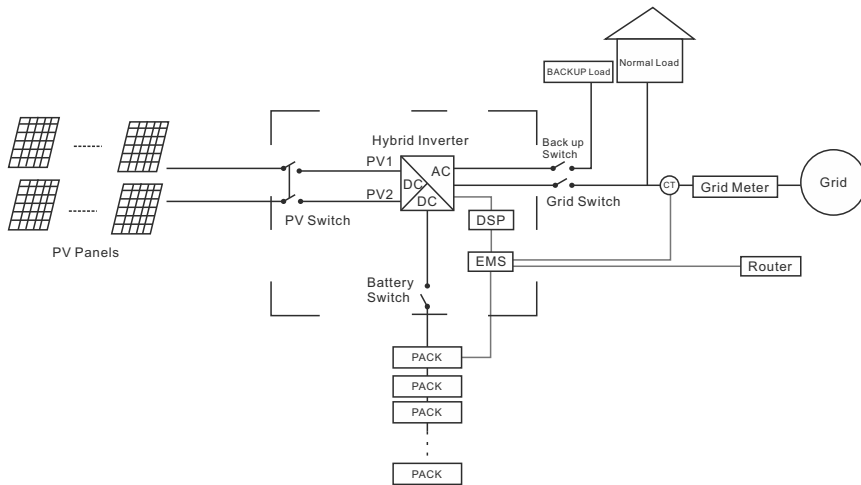

Figure 26 DC-coupled system

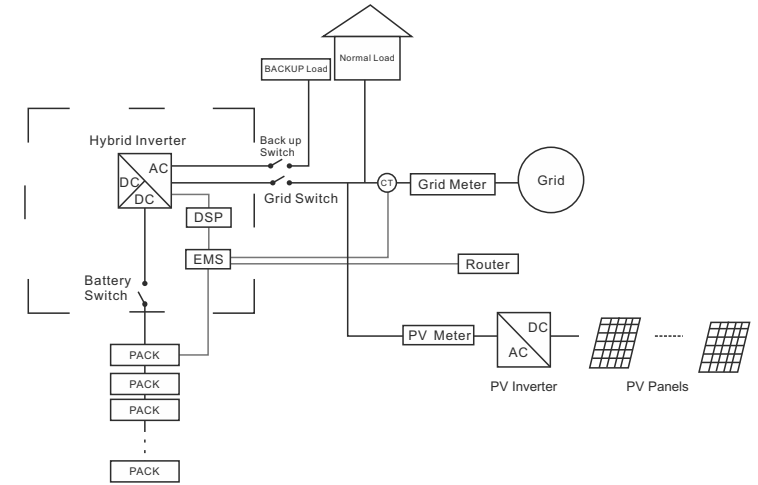

Figure 27 AC-coupled system

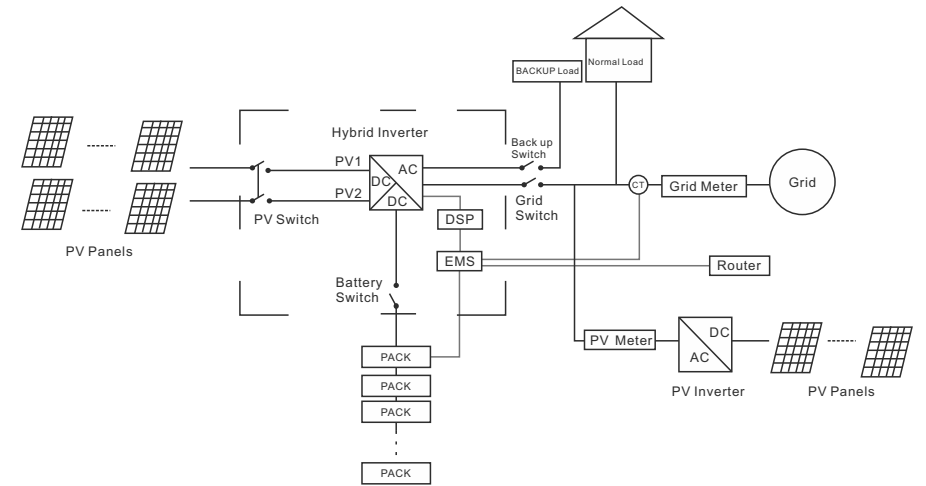

Figure 28 Hybrid-coupled system

03 System Operation

3.1 Switch On

When turning on the system, it is very important to follow the steps below to prevent damage to the system.

WARNING: Please check the installation again before turning on the system.

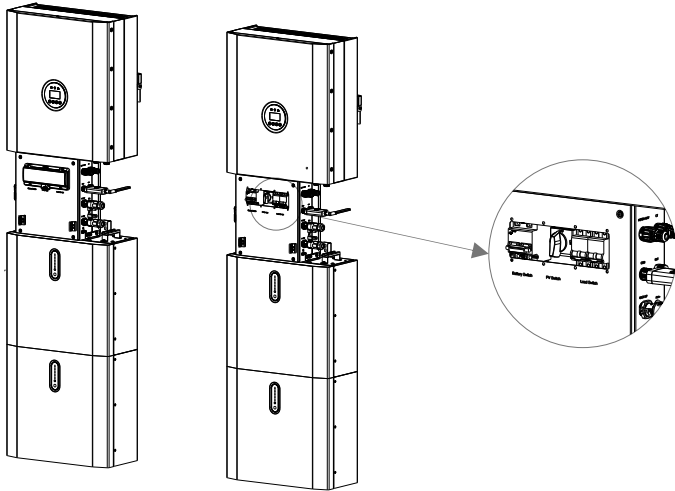

Step 1: Turn on the battery switch on the battery pack. .

Step 2: Press power button on all the batteries until the indicator lights turn on.

Step 3: Turn on the external PV switch.

Step 4: Turn on the external grid switch.

Step 5: If backup load is applied, turn on the external Backup switch.

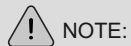

NOTE:

The Backup switch is only used when a backup load is applied.

Step 6: Open the battery switch cover and turn on the battery switch on the cable box of inverter..

Step 7: Close the battery switch cover and the outer shell of the cable box..



NOTE:

If PV=0V under sunshine, please check whether PV is connected reversely or whether the circuit is normal.



NOTE:

Appliances such as air conditioner are required at least 2-3 minutes to restart because it is required to have enough time to balance refrigerant gas inside of circuit. If a power shortage occurs and recovers in short time, it will cause damage to your connected appliances. To prevent this kind of damage, please check manufacturer of air conditioner if it is equipped with time-delay function before installation. Otherwise, this inverter will trigger overload fault and cut off output to protect your appliance but sometimes it still causes internal damage to the air conditioner.

3.2 Switch Off

Step 1: Open cable box outer shell on the inverter, open the battery switch cover and turn off the battery switch.

Step 2: Turn off the external grid switch.

Step 3: If backup load is applied, turn off the external backup switch.

Step 4: Turn off the external PV switch on the cable box.

Step 5: Open cable box outer shell beside the battery pack, open the battery switch cover and turn off the battery switch.

Step 6: Press the power button on all the batteries, till the lights turn off.

Step 7: Close the battery switch cover and the outer shell of cable box.

3.3 Emergency Procedure

When the E8KT/E10KT/E12KT energy storage system appears to be running abnormally, you can turn off the grid-connected main switch that directly feeding the BESS, and turn off all load switches within the BESS, turn off the battery switch at the same time. To prevent a potentially fatal personal injury, if you want to repair or open the machine after the power is switched off, please measure the voltage at the input terminals with a suitably calibrated voltage tester. Before working on this equipment, please confirm that there is no grid electric supply to the BESS! The upper cover plate cannot be opened until the DC-link capacitance inside the battery modules discharges completely about 15 minutes later.

3.3.1 Emergency Handling Plan

1. Disconnect the AC breaker.
2. Check the control power supply. If it is OK, return the power supply to find out the reason.
3. Please record every detail related to the fault, so Company can analyse and solve the fault. Any operation of equipment during a fault is strictly forbidden, please contact Company as soon as possible.
4. As battery cells contain a little Oxygen inside and all cells have got explosion-proof valves, explosion hardly happens.
5. When the indicator light on the battery shows a red fault, check the fault type through the communication protocol, and contact our after-sales service personnel for advice.

3.3.2 Hazards

If the battery pack leaks electrolyte, avoid contact with the leaking liquid or gas. If one is exposed to the leaked substance, immediately perform the actions described below:

Inhalation: Evacuate the contaminated area, and seek medical attention.

Eye contact: Rinse eyes with running water for 5 minutes, and seek medical attention.

Contact with skin: Wash the affected area thoroughly with soap and water, and seek medical attention.

Ingestion: Induce vomiting and seek medical attention.

3.3.3 Fire

If a fire breaks out in the place where the battery pack is installed, perform the following countermeasures:

Fire extinguishing media

During normal operation, no respirator is required. Burning batteries can not be extinguished with a regular fire extinguisher, this requires special fire extinguishers such as the Novec 1230, the FM-200 or a dioxin extinguisher. If the fire is not from a battery, normal ABC fire extinguishers can be used for extinguishing.

Fire -fighting instructions

1. If fire occurs when charging batteries, if it is safe to do so, disconnect the battery pack circuit breaker to shut off the power to charge.
2. If the battery pack is not on fire yet, extinguish the fire before the battery pack catches fire.
3. If the battery pack is on fire, do not try to extinguish but evacuate people immediately.



There may be a possible explosion when batteries are heated above 150°C. When the battery pack is burning, it leaks poisonous gases. Do not approach.

Effective ways to deal with accidents

Battery in dry environment: Place damaged battery into a segregated place and call local fire department or service engineer.

Battery in wet environment: Stay out of the water and don't touch anything if any part of the battery, inverter, or wiring is submerged.

Do not use a submerged battery again and contact the service engineer.

04 EMS Introduction and Set up

4.1 Function Description

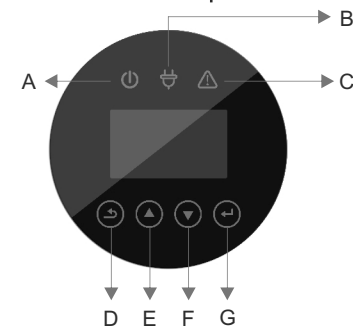

Figure 29 E8KT/E10KT/E12KT EMS Interface

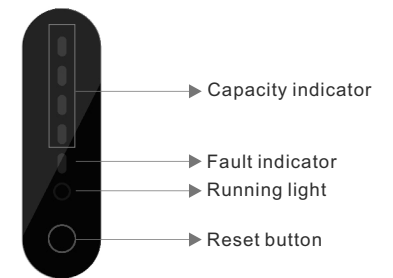

Figure 30 PACK Interface

Object	Name	Description
A		Grid connection
B	Indicator LED	Off-grid
C		Red: The inverter is in fault.
D	Button Function	Return Button: Escape from current interface or function. Enter the setting interface.

E	Button Function	Up button: Move cursor to upside or increase value.
F		Down Button: Move cursor to downside or decrease value.
G		ENT Button: Confirm the selection.

LED indicator description

Table 4.1 LED working status indication

status	Normal/Alarm/Protection	ON/OFF	RUN	ALM	Power indicator LED				Instructions
		●	●	●	●	●	●	●	
Shut down	dormancy	off	off	off	off	off	off	off	All off
Standby	Normal	light	Flash one time	off	According to battery indicator				standby mode
	Alarm	light	Flash one time	Flash three times	According to battery indicator				Module low voltage
charge	Normal	light	light	off	According to battery indicator (Power indicator highest LED flashes two)				The maximum power LED flashes twice, and the ALM does not flash when an overcharge alarm occurs
	Alarm	light	light	Flash three times	According to battery indicator				
	Overcharge protection	light	light	off	light	light	light	light	If there is no mains electricity, the indicator light turns to standby
	Temperature, overcurrent, failure, protection	light	off	light	off	off	off	off	Stop charging
Discharge	Normal	light	Flash three times	off	According to battery indicator				
	Alarm	light	Flash three times	Flash three times	According to battery indicator				
	Undervoltage protection	light	off	off	off	off	off	off	Stop discharging
	Temperature, overcurrent, short circuit, reverse connection, failure protection	light	off	light	off	off	off	off	Stop discharging
Failure		off	off	light	off	off	off	off	Stop charging and discharging

4.2. Display and Setting

4.2.1 General settings

After the machine is installed, you can use it by following the steps below. If you have more requirements for setting, you can refer to Section 4.3 Press ESC button to enter the setting interface and the default password is 00000.

Menu Level 1	Menu Level 2	Menu Level 3	Menu Level 4	Menu Level 5	Menu Level 6	Menu Level 7	Menu Level 8	Default Selection	Comment		
SET UP	Enter Password (Default 00000)	SYS Setting	Work Mode	Self Consume	Charge from Grid	Enable	charge time	00:00-23:59	The energy generated by the solar panels will be used in the following order: Feed the home loads; Charge the battery and then, feed into the grid. When the sun is not present, the load will be supported by the battery to enhance self-consumption. If the power supply from the batteries is not sufficient, the grid will support the load demand.		
							Max SOC(0%~100%)	100% (After charging to the set value, the grid will stop charging the battery.)			
				Peak SHIFT	Time Setting	charge start1 charge end1 discharge start1 discharge end1 charge start2 charge end2 discharge start2 discharge end2	set charging and discharging time	Disable	This mode is designed for time-use mode. The customer can set up the desired charging/discharging time & power via the inverter screen or APP.		
										Charge	Manually forces the system to charge the batteries from the grid.
									DISCHG	Manually forces the system to discharge to the connected load.	
									BAT Priority	Disable	The battery is only used as a backup power supply when the grid fails. As long as the grid works, the batteries won't be used to power the loads. The battery is charged with the power generated by the PV system or from the grid.

Menu Level 1	Menu Level 2	Menu Level 3	Menu Level 4	Menu Level 5	Menu Level 6	Menu Level 7	Menu Level 8	Default Selection	Comment		
		Zero export	Enable	Disable			Disable	Disable	Allows the user to stop the system exporting to the grid. Or, if enabled, to set the export power limit.		
				Enable							
			Power	0-Rated AC output power						set the export power limit	
			CT or METER	CT						CT	CT option is used for measuring the system current.
				Meter							
		AC Couple	Disable			Disable	Allows the user to connect an external inverter to the system (either instead of PV, or in-addition to PC - Hybrid mode).				
			Enable								
		Grid STD	1. China			Local	Allows the user to select the country that the system is installed in.				
			2. Germany								
			3. Australia	AUS-A							
				AUS-B							
AUS-C											
4. Italy	CEI0-21										
	CEI0-21 ACEA										
5. Spain											
6. UK											
7. Hungary											
8. Belgium											
9. New Zealand											

Menu Level 1	Menu Level 2	Menu Level 3	Menu Level 4	Menu Level 5	Menu Level 6	Menu Level 7	Menu Level 8	Default Selection	Comment				
			10. Greece										
			11. France										
			12. Bangkok										
			13. Thailand										
			14. South Africa										
			15. 50549										
			16. Brazil										
			17. 0126										
			18. Ireland										
			19. Israel										
			20. Poland										
			21. Chile	Chile_BT									
				Chile_HD									
				Chile_LD									
			22. Local										
			23. 60Hz										
			Language	1. 中文							English	Allows the user to select Chinese, English or Italian language.	
				2. English									
				3. Italian									
			Date/Time	Set time, date and day								Allows the user to set the time, date and day.	
			CT self-check	Cut off all load then confirm								This action must be performed when the inverter is externally connected to the CT. Before the CT self-check, the inverter needs to be connected to the power grid and the battery. The backup circuit breaker and normal load breaker needs to be disconnected. The CT self-check takes about 1~5 minutes.	

CT self-check steps:

Step 1: Open the external CT wiring port, the arrow points to the direction of the power grid, put the wire into the external CT card slot, and buckle the buckle.

Step 2: Disconnect the backup loads and the normal loads.

Step 3: Connect the battery pack and Grid.

Step 4: Perform CT self-check via LCD.

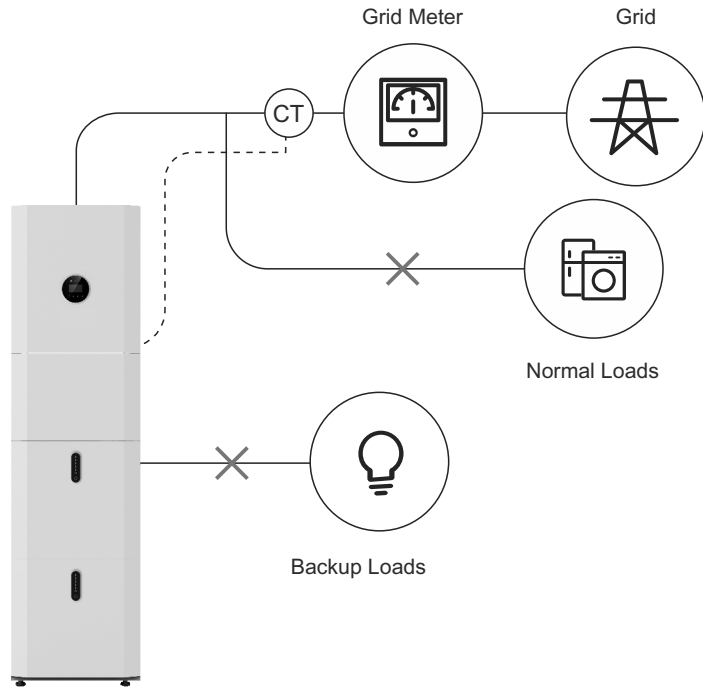

4.3 Configuration Menus Overview

Menu Level 1	Menu Level 2	Menu Level 3	Menu Level 4	Menu Level 5	Menu Level 6	Default Selection	Comment		
SET UP	Enter Password (Default 00000)	SYS Setting	Work Mode	Self Consume	Charge from Grid Enable Disable (default)	Enable	The energy generated by the solar panels will be used in the following order: Feed the home loads; Charge the battery and then, feed into the grid. When the sun is not present, the load will be supported by the battery to enhance self-consumption. If the power supply from the batteries is not sufficient, the grid will support the load demand.		
				Peak SHIFT	Time Setting	Disable	This mode is designed for time-use mode. The customer can set up the desired charging/discharging time & power via the inverter screen or APP.		
					Charge		Manually forces the system to charge the batteries from the grid.		
					DISCHG		Manually forces the system to discharge to the connected load.		
			BAT Priority			Disable	The battery is only used as a backup power supply when the grid fails. As long as the grid works, the batteries won't be used to power the loads. The battery is charged with the power generated by the PV system or from the grid.		
			PV input			Independent	Independent	Allows the user to change the PV array configuration (wiring changes would also apply!) .When parallel input is set to be independent mode, PV power will be imbalanced.	
			Parallel						
			CV						
			Zero export			Enable	Disable	Disable	Allows the user to stop the system exporting to the grid.

Menu Level 1	Menu Level 2	Menu Level 3	Menu Level 4	Menu Level 5	Menu Level 6	Default Selection	Comment
					Enable		Or, if enabled, to set the export power limit.
				Power	set the export power limit(Range: 0~rated power)		If Enable is selected, the user will be prompted to enter the power.
			DRM Enable	Disable Enable		Disable	Only applicable in Australia and New Zealand at this time.
			EPS Enable	Disable Enable		Enable	Enables the Backup output (the Load Switch needs to be turned ON).
			Remote CTRL	Disable Enable		Disable	Allows control via RS485 (Scada system for example).
			Start Delay	20...300Seconds		30Seconds	This is the boot delay from when power is applied to the inverter.
			CEI SPI Ctrl	Disable Enable		Disable	This function is only applicable to use via DRM for remote control (Australian and New Zealand markets only).
			GFCI CHK ENB	Disable Enable		Enable	Ground fault monitoring on the AC grid connection.
			DOD Enable	Disable Enable		Enable	Depth of discharge. This should always be enabled. Disabling will result in the battery discharging to 0%.
			Generator	Disable Enable		Disable	This option allows the user to install a secondary means of generation. For example, wind generator or diesel generator.
			CT or METER	CT		CT	CT option is used for measuring the system current.

Menu Level 1	Menu Level 2	Menu Level 3	Menu Level 4	Menu Level 5	Menu Level 6	Default Selection	Comment
				Meter			Meter option is used for measuring the system current.
			AC Couple	Disable Enable		Disable	Allows the user to connect an external inverter to the system (either instead of PV, or in-addition to PC - Hybrid mode).
			ISLAND	Disable Enable		Enable	When enabled, the inverter will continue to export power via the BACKUP port in the event grid disconnection (power cut).
			BAT Type	Lead-Acid LFP	FLOAT-VOLT EQCHAR VOLT BAT CAP BAT OVP	LFP	Select the battery type.
			DISC Depth	10%~90%		90%	Sets the maximum depth of discharge during grid connected state.
			OFFGRID DOD	0%~100%		90%	Sets the maximum depth of discharge when off-grid.
			CHG CURR	1~160A		160A	Sets the maximum battery charge current.
			DISC Power	0%~100%		100%	Sets the maximum discharge power - % of rated output.
			CHG Power	1%~100%		100%	Sets the maximum charge power - % of rated output.
			BAT End Volt	40~48V		43.2V	Sets the voltage that is seen as 0% remaining.
			BAT Wake-up	Enable	Disable	Enable	If enabled the battery will constantly monitor state of charge and depth of discharge. If time option is selected, the battery will wake up and check

Menu Level 1	Menu Level 2	Menu Level 3	Menu Level 4	Menu Level 5	Menu Level 6	Default Selection	Comment	
					Enable		the state of charge and depth of discharge at the interval set.	
				Time	Set time		If time is selected the user will be prompted to enter a value 0...300 minutes.	
			Heating FLIM	Automatic		Automatic	Allows the user to enable or disable the heating film installed within the battery modules. Automatic means the system measures the Outside temperature and turns the film on as needed. Only applicable if heating film is requested at time of ordering.	
				ON				
				OFF				
			BMS DOD	Disable		Disable	Leave disabled. The inverter will monitor depth of discharge.	
				Enable				
			Maintain SOC	Disable		Enable	Disable: The minimum SOC will not be maintained.	
				Enable			Enable: The minimum SOC 2% is maintained. When the battery SOC is less than 2%, the grid charges the battery pack to 5% through the inverter.	
			Force Wake	Disable		Disable	Enabling this option means the battery will always remain online and will not go to sleep.	
				Enable				
		Grid STD	1. China		Local		Allows the user to select the country that the system is installed in.	
			2. Germany					
			3. Australia	AUS-A				
				AUS-B				
				AUS-C				
			4. Italy	CEI0-21				
		CEI0-21 ACEA						

Menu Level 1	Menu Level 2	Menu Level 3	Menu Level 4	Menu Level 5	Menu Level 6	Default Selection	Comment			
			5. Spain							
			6. UK							
			7. Hungary							
			8. Belgium							
			9. New Zealand							
			10. Greece							
			11. France							
			12. Bangkok							
			13. Thailand							
			14. South Africa							
			15. 50549							
			16. Brazil							
			17. 0126							
			18. Ireland							
			19. Israel							
			20. Poland							
		21. Chile	Chile_BT							
			Chile_HD							
			Chile_LD							
			22. Local							
			23. 60Hz							
		Run Setting	REACT MODE	Power Factor				L0.00~L1.00 C0.00~C1.00	Enable - PF 1.0	The inverter can monitor reactive power in several ways. This setting is set according to the selected grid standard and should not be changed.
				React Power				L00%~L60% C00%~C60%		
				QU Curve		Disable				
				QP Curve						

Menu Level 1	Menu Level 2	Menu Level 3	Menu Level 4	Menu Level 5	Menu Level 6	Default Selection	Comment
			GRID POWER	0...100%		100%	Limit or increase the power exported from the system to the grid.
			INV VOLT MAX	VOLT (S1)	set upper limit voltage	280Vac	These settings should not be altered. They are set automatically according to the country selected within Grid Setting. If the inverter sees that these values have been reached, or exceeded, then the inverter will stop generating.
					set protection time	1000ms	
				VOLT (S2)	set upper limit voltage	285Vac	
					set protection time	400ms	
			INV VOLT MIN	VOLT (S1)	set lower limit voltage	150Vac	
					set protection time	1000ms	
				VOLT (S2)	set lower limit voltage	120Vac	
					set protection time	400ms	
			INV FREQ MAX	FREQ (S1)	set upper limit frequency	55Hz	
					set protection time	500ms	
				FREQ (S2)	set upper limit frequency	55Hz	
					set protection time	500ms	
			INV FREQ MIN	FREQ (S1)	set lower limit frequency	45Hz	

Menu Level 1	Menu Level 2	Menu Level 3	Menu Level 4	Menu Level 5	Menu Level 6	Default Selection	Comment
					set protection time	500ms	
				FREQ (S2)	set lower limit frequency	45Hz	
					set protection time	500ms	
			GRID U MAX	Set max Grid voltage		280Vac	
			GRID U MIN	Set min Grid voltage		130Vac	
			GRID F MAX	Set max Grid frequency		55Hz	
			GRID F MIN	Set min Grid frequency		45Hz	
			OVER VOLT	Enable	Disable	270V	
					Enable		
			UNDER VOLT	Enable	Disable	Disable	
					Enable		

Menu Level 1	Menu Level 2	Menu Level 3	Menu Level 4	Menu Level 5	Menu Level 6	Default Selection	Comment
				VOLT	set voltage (If enabled,Once the AC output voltage is lower than this set value, the output power will start to decrease.)	200V	
			OVER FREQ	Enable	Disable	Disable	
					Enable		
			FREQ	set frequency (If enabled,Once the AC output frequency exceeds this set value, the output power will start to decrease.)		52Hz	
			UNDER FREQ	Enable	Disable	Disable	
					Enable		
			FREQ	set frequency (If enabled,Once the AC output frequency is lower than this set value, the output power will start to decrease.)		48Hz	

Menu Level 1	Menu Level 2	Menu Level 3	Menu Level 4	Menu Level 5	Menu Level 6	Default Selection	Comment
			REACT RESP	6...60 Seconds		10 Seconds	This is the time it takes for the exported reactive power to reach the grid standard level. This setting should not be changed and is set according to the grid standard.
			VRT ENABLE	Disable	Enable	Enable	Voltage-ride-through. This setting should not be changed and is set automatically according to the grid standard.
				Enable			
			POW SI RATE	0...300%		100%	This is the rate of change of the output. This setting should not be changed and is set according to grid standard. 100% means that the output will hit full power within 1 minute.
		485 Address	1...32			1	Allows the user to select the RS485 address for the COM port.
		Baud Rate	1. 2400bps		9600bps		Allows the user to select the RS485 serial baud rate for the COM port.
			2. 4800bps				
			3. 9600bps				
		Language	1. 中文		English		Allows the user to select Chinese, English or Italian language.
			2. English				
			3. Italian				
		Backlight	20...120 seconds			20 seconds	Allows the user to select how long the display back light remains lit.
		Date/ Time	Set time, date and day				Allows the user to set the time, date and day.
		Clear REC	Cancel		Cancel		Clears all stored records.
			Confirm				
			Old password			00000	

Menu Level 1	Menu Level 2	Menu Level 3	Menu Level 4	Menu Level 5	Menu Level 6	Default Selection	Comment	
		Password	New password					Allows the user to change the programming password.
			Confirm new password					
		Maintenance	User cannot access					Not accessible to user.
		Factory RESET	Cancel			Cancel		Resets the system to factory default settings.
			Confirm					
		Auto Test	Only applicable in Italy					Only applicable in Italy.
CT self-check	Cut off all load then confirm					This action must be performed when the inverter is externally connected to the CT. Before the CT self-check, the inverter needs to be connected to the power grid and the battery. The backup circuit breaker and normal load breaker needs to be disconnected. The CT self-check takes about 1-5 minutes.		
Inquire	INV Module					Shows the user what model of inverter is in use.		
	Module SN					Shows the user the serial number of the inverter.		
	Firmware					Shows the user the firmware version.		
	Record					Shows the user the active faults or errors.		
	BMS Info					Shows the user the battery modules connected and connection state.		
Statistic	Time stat	Run:					Shows the user the hours run of Inverter and Grid connection.	
		Grid:						

Menu Level 1	Menu Level 2	Menu Level 3	Menu Level 4	Menu Level 5	Menu Level 6	Default Selection	Comment		
		Unit: hours							
		Conne Time	Times:						Shows the number of times the inverter is connected to the grid.
			Peak Power	History:					Shows the user the total generated watts and today's generated watts.
		Today:							
		Units: watts							
		E-Today	PV: xx kWh						Shows the user what was generated today.
			Meter: xx kWh						
			Grid: xx kWh						
			Load: xx kWh						
			Charge: xx kWh						
		E-Month	PV: xx kWh						Shows the user what was generated this month.
			Meter: xx kWh						
			Grid: xx kWh						
			Load: xx kWh						
		E-Year	PV: xx kWh						Shows the user what was generated this year.
			Meter: xx kWh						
			Grid: xx kWh						
			Load: xx kWh						
E-Total	PV: xx kWh						Shows the user what has been generated since the system was installed.		
	Meter: xx kWh								
	Grid: xx kWh								
	Load: xx kWh								
	Charge: xx kWh								
	Discharge: xx kWh								

05 Battery Storage and Recharging

5.1 Battery storage requirements

1. Storage environment requirements:

- Ambient temperature: 0°C~40°C; recommended storage temperature: 20°C~30°C;
- Relative humidity: 0%RH~90%RH;
- In a dry, ventilated and clean place;
- No contact with corrosive organic solvents, gases and other substances;
- No direct sunlight;
- Less than 2 meters from any heat source.

5.2 Storage expirations

In principle, it is not recommended to store the battery for a long time. Be sure to use it in time. The stored batteries should be disposed according to the following requirements.

Table 5.2 Stored lithium battery recharging interval

Required Storage Temperature	Actual Storage Temperature	Recharging Cycle
0°C ~ +40°C	0°C ≤ T ≤ 30°C	12 months
	30°C < T ≤ 40°C	8 months

- 1.If a battery is deformed, broken or leaking, discard it immediately regardless of its storage time.
- 2.The allowable maximum stored battery recharging period is 3 years and the allowable maximum stored battery recharging times is 3. For example, if recharging is performed once every 8 months, the allowable maximum recharging times is 3 times; if recharging is performed once every 12 months, the allowable maximum recharging times is 3 times; if the allowable maximum stored battery recharging period or times is exceeded, it is recommended to discard the battery.
- 3.A lithium battery will have its capacity decreasing after being stored for a long time, and typically will have its capacity irreversibly decreasing by 3%~10% after being stored at the recommended storage temperature for 12 months. If the customer conducts the discharge test and acceptance according to the specification, there is a risk that the battery with a capacity less than 100% after being stored will fail the test.

5.3 Inspection before battery recharging

Before recharging a battery, check its appearance: Deformation/Shell damage/Leakage

06 Stick Logger Quick Guide

6.1 Download APP

Step 1: Scan the QR Code on the right side and download the APP.



IPhone: Search "SOLARMAN Smart" in Apple Store.
Android: Search "SOLARMAN Smart" in Google Play.

6.2 Stick Logger Installation

Step 1: Assemble logger to the inverter communication interface as shown in the diagram.

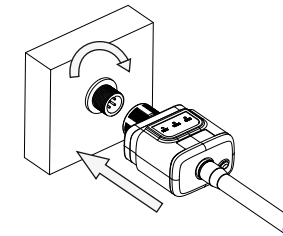

Warning

Please do not hold the logger body to rotate while install or remove the logger.

6.3 Logger Status

6.3.1 Check Indicator light

Lights	Implication	Status Description(All lights are single green lights.)
	Communicate with router	1.Light off: Fail to connect to the router. 2.On 1s/Off 1s(Slow flash): Successful connection to the router. 3.Light keeps on: Successful connection to the server. 4.On 100ms/Off 100ms(Fast flash): Distributing network fast.
	Communicate with inverter	1.Light keeps on: Logger connected to the inverter. 2.Light off: Fail to connect to the inverter. 3.On 1s/Off 1s(Slow flash): Communicating with inverter.
	Logger running status	1.Light off: Running abnormally. 2.On 1s/Off 1s (Slow flash): Running normally. 3.On 100ms/Off 100ms(Fast flash): Restore factory settings.

The normal operation status of the stick logger, when router connected to the network normally:

- 1.Successful connection status with serve: NET light keeps on after the logger powered on.
- 2.Logger running normally: READY light flashes.
- 3.Successful connection status with inverter : COM light keeps on.

6.4 Abnormal State Processing

If the data on platform is abnormal when the stick logger is running, please check the table below and according to the status of indicator lights to complete a simple troubleshooting. If it still can not be resol-ved or indicator lights status do not show in the table below, please contact our Customer Service..(Note: Please using the following table query after power-on for 2mins at least.)

NET 	COM 	READY 	Fault Description	Fault Cause	Solution
Any state	OFF	Slow flash	Communicate with inverter abnormally	1.Connection between stick logger and inverter loosen. Inverter does not match with stick logger's communication rate.	1.Check the connection between stick logger and inverter. Remove the stick logger and install again. 2.Check inverter's communication rate to see if it matches with stick logger's. 3.Long press Reset button for 5s, reboot stick logger.
OFF	ON	Slow flash	Connection between logger and router abnormal	1.Stick logger does not have a network. 2.Antenna abnormal 3.Router WiFi signal strength weak.	1.Check if the wireless network configured. 2.Check the antenna, if there is any damage or loose. 3.Enhance router WiFi signal strength. Long press Resetbutton for 10s, reboot stick logger and networking again.
Slow flash	ON	Slow flash	Connection between logger and router normal, connection between logger and remote server abnormal.	1.Router networking abnormal. 2.The server point of logger is modified. 3.Network limitation, server cannot be connected.	1.Check if the router has access to the network. 2.Check the router's setting, if the connection is limited.
OFF	OFF	OFF	Power supply abnormal	1.Connection between stick logger and inverter loosen or abnormal. 2.Inverter power insufficient. 3.Stick Logger abnormal.	1.Connection between logger and router normal, connection between logger and remote server abnormal.
Fast flash	Any state	Any state	SMARTLINK networking status	Normal	1.Exit automatically after 5mins. 2.Long press Reset button for 5s, reboot stick logger. 3.Long press Reset button for 10s, restore factory settings.
Any state	Any state	Fast flash	Restore factory settings	Normal	1.Exit automatically after 1mins. 2.Long press Reset button for 5s, reboot stick logger. 3.Long press Reset button for 10s, restore factory settings.

6.5 Usage Methods and Notices for Reset Button

6.5.1 Usage methods and key-press descriptions for reset button

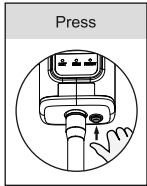

Key-press	Status Description	Light Status
Short press 1s	SMARTLINK rapid networking status.	NET light flashes fast for 100ms.
Long press 5s	Rebooting the stick logger.	All lights are extinguished immediately.
Long press 10s	Resetting the stick logger.	1.All lights are extinguished after 4s. 2.READY light flashes fast for 100ms.

6.5.2 Notice



Notice

Do not remove waterproof plug.



07 SOLARMAN Smart APP

7.1 Registration

Go to SOLARMAN Smart and register. Click "Register" and create your account here.

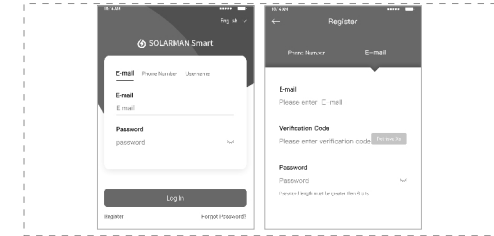

7.2 Create a Plant

Click "Add Now" to create your plant.

Please fill in plant basic info and other info here.

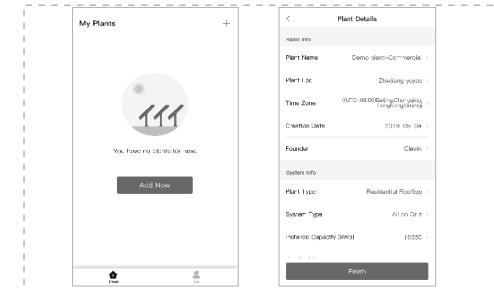

7.3 Add a Logger

Method 1: Enter logger SN manually. Method 2: Click the icon in the right and scan to enter logger SN You can find logger SN in the external packaging or on the logger body.

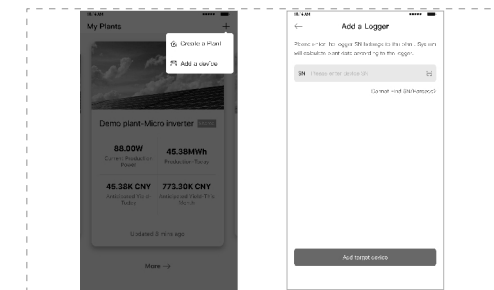

7.4 Network Configuration

After the logger is added, please configure the network to ensure normal operation. Go to "Plant Details"->"Device List", find the target SN and click "Networking".

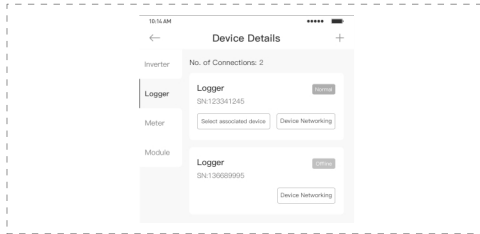

Step 1 : Confirm Wi-Fi Info

Please make sure your phone has connected to the right Wi-Fi network. And click "Start".

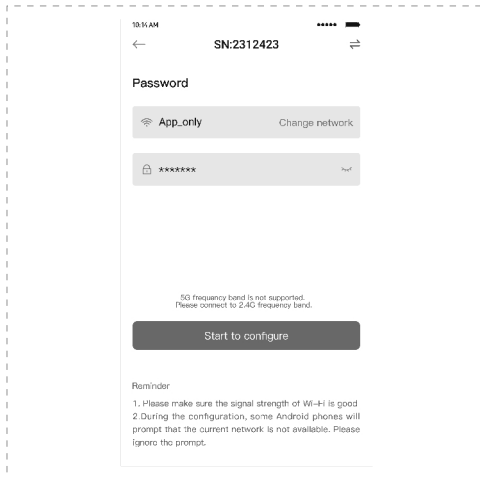

Notice

5G WiFi is not supported .
Special characters (e.g. , ; " = " `) in router name and password are not supported.

Step 2 : Connect to AP network

Click "Go to connect" and find the right "AP_XXXXX" network (XXXXX refers to logger SN). If the password is required, you can find the password on the logger body. Go back to SOLARMAN Smart APP, after connecting to AP network.

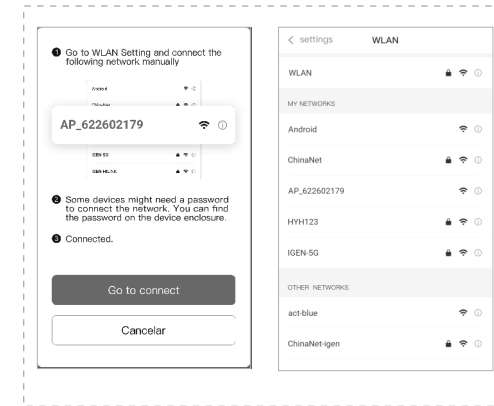

Step 3 : Auto Configuration

Please wait for a while to complete the configuration. Then system will switch to the following page. Click "Done" to check plant data. (Usually, the data will be updated in 10 mins)

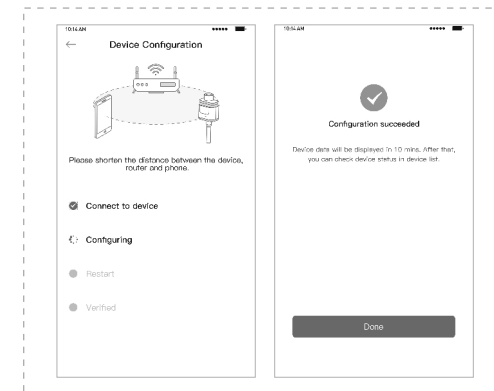

If configuration failure occurs, please check the following reason and try it again.

- (1) Make sure WLAN is ON.
- (2) Make sure WiFi is normal.
- (3) Make sure wireless router does not implement the white-black list.
- (4) Remove the special characters in Wi-Fi network.
- (5) Shorten the distance between the phone and device.
- (6) Try to connect to other Wi-Fi.

08 Alarm Code And Error Code

8.1 Alarm code

Codes	English description
W00	Grid Volt Low
W01	Grid Volt High
W02	Grid Frequency Low
W03	Grid Frequency High
W04	Solar Loss
W05	Bat Loss
W06	Bat Under Volt
W07	Bat Volt Low
W08	Bat Volt High
W09	Over Load
W10	GFCI Over
W11	LN Reverse
W12	Fan Fault
W13	BAT Power Down
W14	BMS Discharge Over Current
W15	BMS charge Over Current
W16	BMS Over Volt
W17	BMS Over Temp
W18	BMS Discharge Low Temp
W19	BMS Volt Imbalance
W20	BMS Communicate Fault
W21	BMS Under Volt
W22	BMS Chg Temp Low
W23	BMS Severe Over Volt
W24	BMS Severe Over Temp
W25	BMS Updating
W26	BMS Program Version Err

W27	BMS Program Update Fail
W28	CT Reverse
W29	Grid VoltLock Fail
W30	PV off
W31	System Reset

8.2 Error code

Codes	English description
F00	Soft Time Out
F01	INV Volt Short
F02	GFCI Sensor Fault
F04	Bus Volt Low
F05	Bus Volt High
F06	Bus Short Circuit
F07	PV ISO Under Fault
F08	PV Input Short Circuit
F09	Bypass Relay Fault
F10	INV Curr Over
F11	INV DC Over
F12	Ambient Over Temp
F13	Sink Over Temp
F14	Grid Relay Fault
F15	DisChg Curr Over
F16	Chg Curr Over
F17	Current Sensor Fault
F18	INV Abnormal
F19	EPS Relay Fault
F20	Always Over Load
F32	DSP ARM SCI Fault

09 Fault Diagnosis And Solutions

The inverter is easy to maintain. When you encounter the following problems, please refer to the Solutions below, and contact the local distributor if the problem remains unsolved. The following table lists some of the basic problems that may occur during the actual operation as well as their corresponding basic solutions.

Fault diagnosis table

Types	Codes	Solutions
Soft Time Out	F00	(1) Restart the inverter and wait until it functions normally; (2) Contact customer service if error warning continues.
INV Volt Short	F01	(1) Cut off all the power and shut down all the machines; disconnect the load and plug in to restart machines, then check whether the load is short circuited if the fault has been eliminated; (2) Contact customer service if fault remains unremoved.
GFCI Sensor Fault	F02	(1) Cut off all the power, Restart the inverter and wait until it functions normally. (2) Contact customer service if error warning continues.
Bus Volt Low or high	F04 F05	(1) Check the input mode setting is correct. (2) Restart the inverter and wait until it functions normally. (3) Contact customer service if error warning continues.
Bus short circuit	F06	(1) Restart the inverter and wait until it functions normally. (2) Contact customer service if error warning continues.
PV ISO Under Fault	F07	(1) Check for good ground connection.; (2) Check if the earth resistance of PV+ and PV- is greater than 2MΩ; (3) If it is smaller than 2MΩ, check PV string for ground fault or poor ground insulation; if it is greater than 2MΩ, please contact the local inverter customer service once fault is not removed.

Types	Codes	Solutions
PV Input Short Circuit	F08	(1) Check the input mode setting is correct. (2) Disconnect the PV input, restart the inverter and wait until it functions normally. (3) Contact customer service if error warning continues.
Relay Fault	F09 F14 F19	(1) Disconnect the PV input, restart the inverter and wait until it functions normally. (2) Contact customer service if error warning continues.
INV Current Over	F10	(1) Wait five minutes for the inverter to automatically restart; (2) Check whether the load is in compliance with the specification; (3) Contact customer service if error warning continues.
INV DC Over	F11	(1) Restart the inverter and wait until it functions normally. (2) Contact customer service if error warning continues.
Ambient/Sink Temp Over	F12 F13	(1) Restart the inverter, restart the machine after a few minutes of cooling, and observe whether the machine can return to normal. (2) Check if the ambient temperature is outside the normal operating temperature range of the machine. (3) Contact customer service if error warning continues.
Dischg Curr Over	F15	(1) Wait one minute for the inverter to restart; (2) Check whether the load is in compliance with the specification; (3) Contact customer service if error warning continues.
CHG Current Over	F16	(1) Check if battery wiring port is short circuited; (2) Check if charging current is in compliance with presetting; (3) Contact customer service if error warning continues.
Current Sensor Fault	F17	(1) Restart the inverter and wait until it functions normally. (2) Contact customer service if error warning continues.

Types	Codes	Solutions
INV Abnormal	F18	(1) Please contact the distributor.
Communication Fault	F32	(1) Restart the inverter and wait until it functions normally. (2) Contact customer service if error warning continues.
Grid Fault	W00 W01 W02 W03	(1) Check if the local voltage and frequency is in compliance with the machine specification; (2) If voltage and frequency are within the accepted range, then wait 2 minutes for the inverter to function normally; but if no recovery or fault repeats, please contact the local inverter customer service; (3) Contact the local power company if voltage and frequency are beyond range or unstable.
Solar Loss	W04	(1) PV is not connected; (2) Check grid connection; (3) Check PV availability.
Bat Loss	W05	(1) Battery is not connected; (2) Check if battery wiring port is short circuited; (3) Contact customer service if error warning continues.
Bat Volt Low	W06 W07	(1) Check the battery availability; (2) Contact customer service if error warning continues.
Bat Volt High	W08	(1) Check if the battery is in line with the presetting; (2) If so, power off and restart; (3) Contact customer service if error warning continues.
Over Load Warning	W09	(1) Wait one minute for the inverter to restart; (2) Check whether the load is in compliance with the specification;
GFCI Over	W10	(1) Check PV string for direct or indirect grounding phenomenon; (2) Check peripherals of machine for current leakage; (3) Contact the local inverter customer service if fault remains unremoved.
LN Reverse	W11	(1) Check whether the installation follows the instructions; (2) Contact customer service if error warning continues.

Fan Fault	W12	(1) Restart the inverter and wait until it functions normally. (2) Contact customer service if error warning continues.
BMS Fault	W14~W27	(1) Please contact the distributor.
CT Reverse	W28	(1) Perform CT self-check; (2) Contact customer service if error warning continues.
Grid VoltLock Fail	W29	(1) Restart the inverter and wait until it functions normally. (2) Contact customer service if error warning continues.
PV off	W30	(1) Restart the inverter and wait until it functions normally. (2) Contact customer service if error warning continues.
System Reset	W31	(1) Restart the inverter and wait until it functions normally. (2) Contact customer service if error warning continues.

10 Product Specifications

Battery Specifications

PACK5.1

Electrical

Energy Capacity	5.12kWh
Battery Type	LFP (LiFePO4)
Depth of Discharge (DoD)	90%
Rated Voltage	51.2V
Operating Voltage Range	44.8~56.5Vdc

Operation

Maximum Charging Current	50A (0.5C)
Maximum Discharging Current	80A (0.8C)
Operating Temperature Range	0°C~+50°C -10°C~+50°C(Built in heating film)
Storage Temperature Range	-20°C ~ +50°C
Humidity	0~95% (No condensation)

BMS

Modules Connection	Max. 8 batteries in parallel
Monitoring Parameters	System voltage, current, cell voltage, cell temperature, PCBA temperature measurement
Communication	CAN and RS-485 compatible
Ventilation Type	Passive and Active Cooling

Physical	
Weight (Kg)	54
Dimension (W×H×D)mm	540*530*240
IP Protection	IP65
Warranty	5 Year Product Warranty, 10 Year Performance Warranty

Model	E8KT	E10KT	E12KT
PV terminal			
Vmax. PV	1100Vd.c.		
Rated Voltage	720Vd.c.		
MPPT Voltage Range	140~1000Vd.c.		
MPPT Range (full load)	380~850Vd.c.	420~850Vd.c.	480~850Vd.c.
MPPT Tracker / Strings	2		
Max. Continuous PV Input Current	15Ad.c.*2		
Isc PV	20Ad.c.*2		
Max. Backfeed Current	0Adc		
Max. Continuous PV Input Power	16000W	20000W	20000W

Battery terminal			
Battery Type	Lithium or lead-acid batteries		
Voltage Range	44~58Vd.c.		
Rated Voltage	51.2Vd.c.		
Maximum Charge/Discharge Current	160Ad.c./160Ad.c.	160Ad.c./200Ad.c.	160Ad.c./200Ad.c.
Maximum Charge/Discharge Power	8000W/8000W	8000W/10000W	8000W/10000W

Grid terminal parameter	
Rated Voltage	230/400Va.c.
Rated Frequency	50Hz/60Hz

Maximum Continuous Input Current	25Aa.c.		
Maximum Continuous Input Power	16000W	17800W	17800W
Rated output Current	11.6Aa.c.	14.5Aa.c.	17.4Aa.c.
Maximum Continuous Output Current	12.8Aa.c.	16Aa.c.	19.2Aa.c.
Power Factor (Cos phi), Adjustable	0.8 leading ~ 0.8 lagging (0.95 leading ~ 0.95 lagging for Germany)		
Maximum Continuous Output Power	8800VA	11000VA	13200VA
Max. Output Fault Current	102Apeak		
Grid Port Inrush Current	Less than 22Apeak		
Grid Port Overcurrent Protection	32A		

Backup load terminal parameter			
Rated Voltage	230/400Vac		
Rated Frequency	50/60Hz		
Rated output Current	10.7Aa.c.	13.3Aa.c.	13.3Aa.c.
Maximum Continuous Output Current	11.6Aa.c.	14.5Aa.c.	14.5Aa.c.
Rated Continuous Output Power	7360W	9200W	9200W
Maximum Output Apparent Power	8000VA	10000VA	10000VA
Max. Output Fault Current	99Apeak		
Backup Load Overcurrent Protection	25A		

General parameter	
Temperature	-25°C to +60°C, derating above 40 °C
Protective Class	Class I
Overvoltage Category	II(DC side), III(AC side)
Ingress Protection	IP65
Altitude	≤ 2000m
Dimension (W×H×D)mm	540*980*240
Weight (Kg)	47
Relative Humidity	0~95% (No condensation)

Topology	High Frequency Isolation
Cooling	Natural Convection
Display	LCD/APP
Communication Interface	RS485/CAN2.0/WIFI
Max. Conversion Efficiency (From Battery)	94.0%
Max. Conversion Efficiency (From PV)	97.6%
Euro Efficiency	97.0%
MPPT Efficiency	99.5%
Protection Function	Short Circuit Protection, AC Leakage Fault Protection, Grounding Fault Protection, Anti-islanding Protection, Overload Protection, Surge Protection , DC Polarity Protection
Certification& Standard	
Grid Regulation	AS/NZS 4777.2, VDE-AR-N4105, VDE0126-1-1
Safety Regulation	IEC/EN 62109-1&2, IEC62040-1,IEC62619
EMC	EN61000-6-1, EN61000-6-2, EN61000-6-3, EN61000-6-4,EN61000-4-16, EN61000-4-18, EN61000-4-29

Table 10.1 Grid specification (single-phase)

Grid Specification	Output Voltage Range (Vac)	Output Frequency Range (Hz)	Boot wait time(S)
China	187-252	49.5-50.2	30
Germany	184-264	47.5-51.5	60
Australia-A	180-265	47-52	60
Australia-B	180-265	47-52	60
Australia-C	180-265	45-55	60
Italy(CEI0-21)	195-264	49.8-50.2	60
Italy(CEI0-21 ACEA)	195-264	49.8-50.2	60
Spain	196-253	48-50.5	180
U.K.	184-264	47-52	180
Hungary	196-253	49-51	300
Belgium	184-264	47.5-51.5	60
W-Australia	180-260	45-52	60
Greece	184-264	49.5-50.5	180
France	184-264	47.5-50.4	60
Bangkok	198-242	49-51	150
Thailand	198-242	47-52	60
S. Africa	180-260	47.0-52	60
50549	184-264	47.5-51.5	60
Brazil	184-264	59.5-60.5	60
0126	184-264	47.5-51.5	60
Ireland	184-264	47-52	180
Israel	195.5~253	47.0~51.5	60
Poland	195.5~253	49.00~50.05	60
Chile-BT	176.0~242	47.5~51.5	60
Chile-HD	198.0~242	49~51	300
Chile-LD	198.0~242	49~51	300
Local	150-280	45.0-55	30
60Hz	184-264	59.5-60.5	60

11 Routine Maintenance

11.1 Maintenance Plan

- ◆ Check if wire connections are loose.
- ◆ Check if cables are aged/damaged.
- ◆ Check if cable insulating ribbon drops.
- ◆ Check if cable terminal is loose, any overheat sign.
- ◆ Check if ground connection is good.

11.1.1 Operating Environment

(Every six months)

Carefully observe whether the battery system equipment is ineffective or damaged; When the system is running, listen to any part of the system for abnormal noise; Check whether the voltage, temperature and other parameters of the battery and other equipment parameters are normal during system operation;

11.1.2 Equipment Cleaning

(Every six months to one year, depending on the site environment and dust content, etc.)Ensure that the ground is clean and tidy, keep the maintenance access route unblocked,and ensure that the warning and guiding signs are clear and intact. Monitor the temperature of the battery module and clean the battery module if necessary.

11.1.3 Cable, Terminal and Equipment Inspection

(Every six months to one year)

- ◆ Check if the cable connections are loose.
- ◆ Check whether the cables are aged / damaged.
- ◆ Check whether the cable tie of the cable has fallen off.
- ◆ Check if the cable terminal screws are loose and the terminal position has any signs of over heating.
- ◆ Check whether the management system of the system equipment, monitoring system and other related equipment are invalid or damaged.
- ◆ Check that the grounding of the equipment is good and the grounding resistance is less than 10 ohms.

11.2 Notes

After the equipment is out of operation, please pay attention to following notes while maintaining :

- ◆ Related safety standards and specifications should be followed in operation and maintenance.
- ◆ Disconnect all the electrical connections so that the equipment would not be powered on.
- ◆ Wait at least 5 minutes after disconnection, so that the residual voltage of the capacitors drops to a safe voltage. Use a multimeter to make sure that the equipment is completely discharged.
- ◆ The equipment should be repaired by professional staff only and it is strictly forbidden for maintenance staff to open equipment modules on their own.
- ◆ Appropriate protective measures should be taken while maintaining, such as insulated gloves, shoes, and anti-noise ear plugs.
- ◆ Life is priceless. Make sure no one would get hurt first.
- ◆ In case of a deep discharge, the battery must be charged to a SOC rate of 30% to 50% if the entire system is static (the battery has not been charged for two weeks or more).

Please contact us in time if there are any conditions that could not be explained in the manual.

12 Quality Assurance

When product faults occur during the warranty period, Company or his partner will provide free service or replace the product with a new one.

Evidence

During the warranty period, the customer shall provide the product purchase invoice and date. In addition, the trademark on the product shall be undamaged and legible. Otherwise, Company has the right to refuse to honor the quality guarantee.

Conditions

- After replacement, unqualified products shall be processed by Company.
- The customer shall give Company or his partner a reasonable period to repair the faulty device.

Exclusion of Liability

In the following circumstances, Company has the right to refuse to honor the quality guarantee:

- The free warranty period for the whole machine/components has expired.
- The device is damaged during transport.
- The device is incorrectly installed, refitted, or used.
- The device operates in harsh environment, as described in this manual.
- The fault or damage is caused by installation, repairs, modification, or disassembly performed by a service provider or personnel not from Company or his authorized partner.
- The fault or damage is caused by the use of non-standard or non-Company.

components or software.

- The installation and use range are beyond stipulations of relevant international standards.
- The damage is caused by unexpected natural factors.

For faulty products in any of above cases, if the customer requests maintenance, paid maintenance service may be provided based on the judgment of Company.