



BLUETTI Balcony Solar System

Energy Independence, Starts Here

Scan the QR code
to learn more





Contents

Chapter 1 1-5

What is BLUETTI
Balcony Solar System?

Chapter 2 6-13

Why BLUETTI
Balcony Solar System?

Chapter 3 14-15

Specifications

Chapter 4 16-17

Pre-order Options

01

What is BLUETTI Balcony Solar System?

Energy Independence, Starts Here



01

BLUETTI Balcony Solar System

The 1st Comprehensive Balcony Power Solution



BLUETTI Balcony Solar System is a highly efficient grid-tied energy storage system that consists of the solar panel, solar charge controller, microinverter, and battery. It stores extra solar energy generated during the daytime and provides power through the night, effectively reducing your peak-hour energy costs and cutting down your carbon footprint.

Energy Independence, Starts Here™



How it works?



Energy Independence, Starts Here

- 1**
Solar panel captures the solar energy during the day.
- 2**
Solar charge controller optimizes the conversion efficiency.
- 3**
Microinverter converts the DC electricity into AC to power your devices.
- 4**
Surplus energy stored in the battery for peak-hour use.

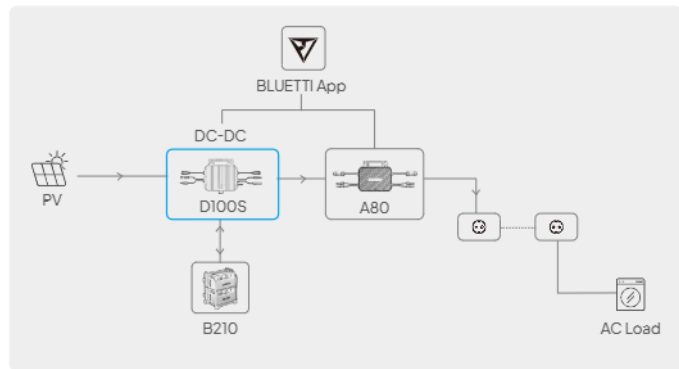



**SAVE ON
BILL**

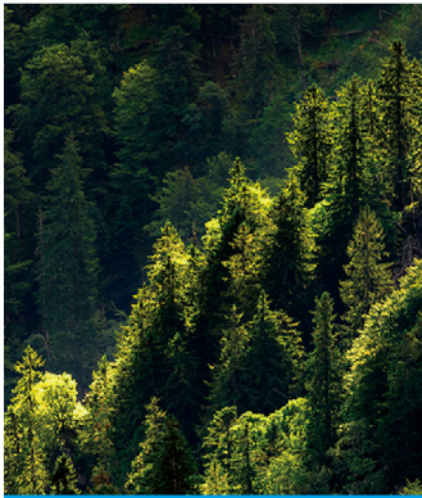

**LOWER CARBON
EMISSIONS**



**POWER THROUGH
THE NIGHT**

Affordable & Renewable Energy

0%
VAT



Up to 750€
Regional Subsidies



Additional
Incentives
for Bundle Case

Heat
Pump

EV

Balcony
Solar
System

* The amount depends on regional guidelines and is subject to change anytime.
For further details, please inquire with your local authorities directly.

02

Why BLUETTI Balcony Solar System?

Energy Independence, Starts Here



Save up to 4.350 € for a 10-year Use

Your Budget-Friendly Energy Solution

By storing the extra solar energy (up to 4,3 kWh) generated during the day and feeding back to your home for night-time use, you can save approximately 435 € per year on energy costs, meaning that your system can pay for itself in 5 years!



* For reference ONLY. The actual savings may vary due to various factors, such as power consumption and local electricity price.



Energy Independence, Starts Here

Up to 98% High Efficiency Minimize Power Loss

The A80 microinverter converts the solar panel's direct current (DC) into alternating current (AC), which can be fed into the grid and ready to juice up household devices directly and efficiently, bringing extended runtime for your appliances.



Dual MPPT
Solar Charge Controller



Higher Efficiency
than Single Controller



Energy
Loss

High Power Density Maximum Solar Harvest

Other Brands Solar Panel

176W/ m²
Surge Power Density

BLUETTI Solar Panel

180W/ m²
Surge Power Density



For reference ONLY.



IP65 – rating Protection Durability and Safety Guaranteed



The balcony solar system is water and dust resistant to maintain excellent performance on your balcony. It also comes with the LiFePO₄ battery for a prolonged lifespan and a 10-year warranty* to spare you a world of hassle.

* The warranty for B210 battery is 5 years.



Energy Independence, Starts Here

Quick Setup in Minutes



1-2 Person (s)



Space-saving



DIY Installation



Plug and Play

Smart Control with BLUETTI App



Track Solar Energy Generation



Stay Informed About Your Savings



Monitor Real-time Power Consumption

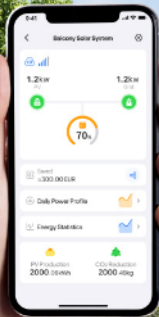

Energy Independence, Starts Here

Fits Anywhere The Sun Shines

Balcony of Flat



Balcony of House



Backyard and Garden

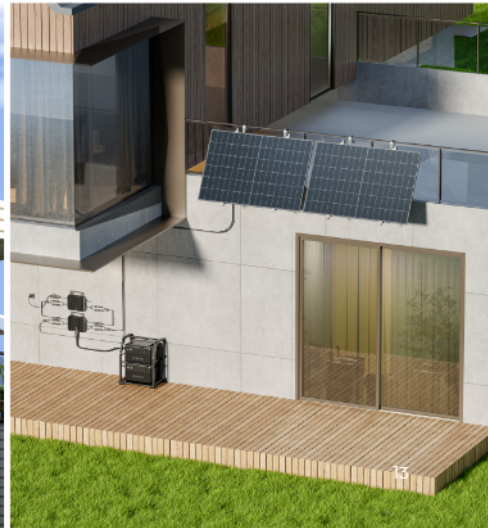

03

Specifications

Energy Independence, Starts Here





Flexible Panel



Glass Panel

A80 Microinverter			
Rated Output	800W (800W-DE)	Maximum Input (PV)	1100W
Rated Output Voltage	230V	MPPT Voltage Range	18-80V
Weight	3.1kg/6.8lb	MPPT Efficiency	99%
Connection Type	Bluetooth & Wi-Fi	Peak Efficiency	98.5%
Ingress Protection	IP67	Dimensions	235x227x47mm (9.2x8.9x1.85in)

D100S Solar Charge Controller			
PV Input Power	1000W	Operating Temperature	-40°C-65°C
MPPT Efficiency	99%	Other Features	Voltage, Temperature Protection
Output Efficiency	98%	Dimensions	235x225x47mm (9.2x8.8x1.8in)
Noise Emission	<40dB	Weight	3kg/6.6lb
Ingress Protection	IP67		

B210 Battery			
Capacity (1 B210 battery)	2,160Wh	Battery Scalability	4,300Wh with Two B210 Batteries
Battery Type	LiFePO ₄	Weight	27.9kg/61.5lb
Operating Temperature	-20°C-40°C	Noise Emission	<45dB
Ingress Protection	IP65	Battery Life Cycles	3,000+ Cycles to 80% Original Capacity

Solar Panel			
Flexible Panel		Glass Panel	
Model No.	BFPV-255	Model No.	BGPV-410
PV Input Power	255W	PV Input Power	410W
Cell Type	PERC MONO	Cell Type	PERC MONO
Protection Rating	IP67	Ingress Protection	IP68
Wind Resistance Rating	37m/s (83 mph)	Wind Resistance Rating	37m/s (83 mph)
Dimensions	1410mmx1000mmx4mm (55.5 inx39.4 inx0.16 in)	Dimensions	1722mmx1134mmx30mm (67.8 inx44.6 inx1.18 in)
Connect Port	MC4	Connect Port	MC4
Weight	7kg/15.4lb	Weight	20.8kg/45lb
Open Circuit Voltage	51V	Open Circuit Voltage	37.4V
Voltage at Pmax	42.4V	Voltage at Pmax	31.42V
Short Circuit Current	6.38A	Short Circuit Current	13.64A

04

Pre-order Options



Choose Your Solutions

Pre-order Starting Oct. 2023



01

The Whole System



- 255W Flexible Panel x 2
- 800W A80 MicroInverter x 1
- D100S Solar Charge Controller x 1
- B210 Battery x 1/2
- BABC-210 Mounting Bracket x 1



- 410W Glass Panel x 2
- 800W A80 MicroInverter x 1
- D100S Solar Charge Controller x 1
- B210 Battery x 1/2
- BABC-210 Mounting Bracket x 1



02

With Battery Storage

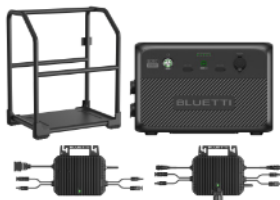

- B210 Battery x 1/2
- 800W A80 MicroInverter x 1
- D100S Solar Charge Controller x 1
- BABC-210 Mounting Bracket x 1



03

Without Battery Storage



- 255W Flexible Panel x 2
- 800W A80 MicroInverter x 1

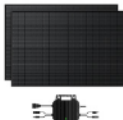

- 410W Glass Panel x 2
- 800W A80 MicroInverter x 1